

# SNOW COUNTRY EXPRESS

## CHRISTMAS VERSION



## WINTER VERSION



Photo above actual quilts.  
Changes have been made to enhance the design.  
Refer to Instructions for accurate pictures.

**All aboard! Snow Country Express!  
Leaving track #29, I want to be there on time!  
Enjoy First Class seats on a wonderful sightseeing journey  
around mountainous pine  
and snow filled countryside!**

Stitch field required 8"x12"  
.art .dst .exp .hus .jef .pes .vip .vp3

## Snow Country Express Supply List

Finished size 54" x 54"



Design: **Snow Country Express** \$130.00 (each student must purchase the design to attend the workshop)

### Fabric Supply List:

3 ½ yards	Light colored tone on tone Background Fabric	½ yard	Binding
1 ¾ yards	Outer Border Fabric & Sashing (length needed for Outer Border)	4 yards	Backing
½ yard	Sashing (in alternate fabric color)	60" x 60"	Batting
6 yards	Shape Flex 101 by Pellon (20" wide)		

### Embroidery Supply List:

Minimum Hoop Requirements: 8" wide x 12" high or **larger** / bring your **largest hoop & grid**

All Hoops should have a **grid/template** (purchase or make one if you don't have one)

10 yards Heavy Weight Tear Away (Pellon #806 Stitch & Tear )

Temporary Adhesive Spray: Suggested **505 Spray Adhesive**

Removable fabric marking pen: Suggested **SewLine Duo Marker & Eraser Med Point tip** (no air erasable pens)

Embroidery Needles 80/12 and 90/14 (both work but some machines prefer one over the other)

Terial Magic Starch (mandatory)

Suggested: 18"x24" Wool Ironing pad suggested and white **Top Cover** by OESD (permanent vinyl covering)

**Basic embroidery kit:** including small double curved scissors, tweezers,

Arrow shaped post it notes by Post-It-Notes (they say: **SIGN** HERE)



**Bobbin Thread:** (light neutral color & black)

**Embroidery Thread: Isacord 40 wt. Embroidery Threads listed:**

### Christmas Colors

#### Greens

5324 Bright Green

5510 Emerald

5610 Bright Mint

6043 Yellowgreen

#### Greys

0112 Leadville

0142 Sterling

1972 Silvery Grey

#### Yellow/Gold

0811 Candlelight

0824 Liberty Gold

#### Black & Whites

0015 White

0020 Black

0870 Muslin

#### Purple/Pink

2702 Grape Jelly

2721 Very Berry

3130 Dawn of Violet

#### Browns

0932 Nutmeg

1233 Pony

1876 Chocolate

#### Reds/ Oranges

1304 Red Pepper

1800 Wildfire

#### Blues

4010 Caribbean Blue

4116 Dark Teal

4240 Spearmint

### Winter Colors

#### Greens

0345 Moss

0453 Army Drab

5934 Moss Green

6043 Yellowgreen

#### Greys

0112 Leadville

0142 Sterling

1972 Silvery Grey

#### Yellow/Gold

0704 Gold

0721 Antique

#### Black & Whites

0015 White

0020 Black

0870 Muslin

#### Purple/Pink

2723 Peony

2810 Orchid

2830 Wild Iris

3130 Dawn of Violet

#### Browns

0932 Nutmeg

1233 Pony

1876 Chocolate

#### Red/Orange

1335 Dark Rust

1911 Foliage Rose

#### Blues

3902 Colonial Blue

3750 Winter Frost

3810 Laguna

4332 Rough Sea

### Sewing Supply List

50wt. Cotton Thread matching the fabric for piecing

Basic sewing kit including scissors, pins, rotary cutter & mat, long straight ruler, etc.

20 ½" Square Ruler by Creative Grids & Jumbo Wonder Clips (to hold fabric away from hoop while embroidering)

Thread conversion chart on page #57 if you want to combine Winter & Christmas blocks!!

Copyright ©Copyright 2021 Claudia Dinnell

No part of this may be reproduced in any form or by any means without written permission from the copyright holder. These designs and instructions are for personal non-commercial use by the original purchaser only and are protected under US & International Laws.

www.claudiascreationsaz.com

# TIPS FOR SUCCESSFUL EMBROIDERY!



Keep these pages accessible, you will need to refer to these “Tips” throughout your embroidery!!  
Follow Claudia’s two step “**Perfect Placement Technique**” for accurately multi-hooping large designs!

## Step #1: Marking the design’s first stitch location on the grid:

- Attach the **hoop and grid** to the module with no fabric.
- **Open the design** to be embroidered.
- Advance to the **embroidery sewing screen**. Embroidery Machines open a design in an editing screen. Touch the icon that moves you to the embroidery sewing screen. Advancing to the embroidery sewing screen takes you to the first stitch of the design, where you are ready to embroider!

**Brother, Babylock & Janome** machines have an automatic center stitch programmed into the machine. You must advance past this “programmed center stitch” to move to the first stitch of my designs. These machines will have an additional icon (usually a +/- key) you will need to touch to move you to first stitch of my design.

The **Basting Box option** must be **turned off** before advancing to the embroidery sewing screen.

- When at first stitch: by hand, lower your needle to touch the grid. Place an arrow shaped post-it-note on the grid so the tip of the arrow touches the tip of the needle. This marks the **first stitch location** of my design on the grid (not the center of the design, not the center of the hoop, but the first stitch of the opened design).
- Raise the needle; remove the hoop and the marked grid from the module.

## Step #2: Hooping the Fabric

- Place the **inner hoop with the grid** on the (stabilized and marked) background fabric. The arrow shaped post-it-note on the grid should be pointing to either the **Needle Alignment** or to the **Placement Line** location on the background fabric. The location is noted in the Embroidery Instructions and will be different for each hooping (it will almost never be the center of the hoop).
- Hoop the (stabilized and marked) fabric with the lines on the grid parallel and perpendicular to the drawn lines on the fabric. The drawn lines need not lie exactly under the lines of the grid, but must be parallel and perpendicular to the lines on the grid. This keeps the larger piece of fabric square and straight as you embroider.
- Remove the grid from the hoop and attach the hoop to the module.
- It may be necessary to re-position the needle exactly over the **mark** indicated in the instructions. Use your **Move Motif Icon** to tweak the needle perfectly over the mark.
- **Needle Alignment** is to place the needle over a specific mark like the drawn crosshair on the fabric
- **Placement Line** is to sew (without thread) over previously sewn stitches to ensure correct placement.
- To watch a demo of the “Perfect Placement Technique” from your computer go to:  
[www.claudiascreationsaz.com](http://www.claudiascreationsaz.com) Select the “Videos” tab and choose Perfect Placement.

## Additional Tips and Helps!

### Tip #1: Built in Basting Box!

Many embroidery machines have a built-in basting box option. When this option is enabled it may add a color stop to the stitching order of the design. This option should be disabled before opening a design. If the basting box option is on or enabled when you advance to the embroidery sewing screen, you would be marking the grid with the first stitch position for the basting box and not the first stitch of the design!

Be sure to disable the basting box option before opening a design. Mark the first stitch of the design with the post-it note arrow.



## Tip #2: Hooping Tips

Place sections of **permanent** double sided tape (**not repositionable**) on the wrong side of the inner hoop. Then flip the inner hoop right side up and place the inner hoop, with the grid inside of it, on the fabric. The doubled sided tape holds the inner hoop to the fabric. This makes it easier to pick up the inner hoop and fabric and place it in the outer hoop with ease. (Always loosen the outer hoop screws as much as possible). Remove the tear away stabilizer from the last hooping to reduce the stabilizer "bulk". Roll the excess fabric in a tube shape and use clips to hold the excess fabric out of the way.

## Tip #3: Unusual Embroidery Instructions:

**Needle Alignment:** This is placed first in the stitching order to align the needle exactly where it goes. It is strictly for needle placement and not to be sewn out (unless indicated). If it is accidentally sewn out it will look like a crosshair. Pick it out!

**Placement Line:** This is a line that is to be sewn **out without thread** over an existing line to ensure correct placement. It is an alignment tool for connecting one hooping to another.

**The blank line after the thread color: Thread Purple # \_\_\_\_\_** (Write your thread Color # on the line) It will help you remember what color you used when you return to embroidering.

## Tip #4: Babylock & Brother Machines

Sometimes these machines like to rotate the design. Don't know why!! Make sure the design on YOUR screen has the same orientation as the picture on the instructions. This is a reminder!!

Babylock & Brother machines may need to rotate the design to look like this!

## Tip #5: Trimming the Blocks

For best accuracy, use a **square ruler** to trim all the blocks. Place the square ruler on the block lining up two sides, then trim. Trimming with a 6" x 24" ruler is **not as accurate** and leads to slips and miss-cuts. If you have difficulty keeping a ruler from moving when you cut, wear quilting gloves to help hold it in place!

## Tip #6 Sewing without Thread

Every machine has a icon where you can advance or move backwards through a design. This is usually used when you "**break a needle**" or "**run out of bobbin thread**" and you need to backup to replace stitches. I use this icon to advance through a design to "**sew without thread.**" As you advance lower & raise the needle often to check the position to be sure you are correctly following the placement line.

**YouTube/ claudiascreationsaz for demo.**

## Fabric Preparation

### Terrial Magic.

Saturate the background fabric in **Terrial Magic**. Spray or pour onto the fabric to saturate.

This product is a heavy starch. The fabric must be very stiff to avoid stretching during embroidery.

Let the fabric almost dry then iron the fabric flat and smooth. (YouTube channel / claudiascreationsaz)

### Woven Interfacing:

Place the woven interfacing (Shape Flex 101 by Pellon) adhesive side down, on the wrong side of the fabric. Spray with water to activate the adhesive. Use your hands to smooth out the moistened Interfacing over the fabric before using the steam iron. Set the steam iron on the center area and hold the iron long enough to dry & seal the two layers together, but not so long that it burns! Pick up the iron and place it close to the first spot. Repeat until all the interfacing is sealed to the fabric. This will "pre-shrink" both fabric and interfacing. The Interfacing will shrink, that is expected. All the edges of the Interfacing should be sealed to the fabric as if they were one piece so they can't be separated. To cover larger pieces of fabric, continue the process by overlapping the pieced sections by ½".

([www.claudiascreationsaz.com](http://www.claudiascreationsaz.com) / Videos / Fabric Prep or YouTube / claudiascreationsaz / Fabric Prep)



## Fabric Preparation for All Blocks & Borders

### Terial Magic.

Saturate the background fabric (shown above) in **Terial Magic**. Spray or pour onto the fabric to saturate. This product is a heavy starch. The fabric must be very stiff to avoid stretching during embroidery. Let the fabric almost dry then iron the fabric flat and smooth. (YouTube channel / claudiascreationsaz Terial Magic)

### Interfacing: Shape Flex 101 by Pellon

Center and Iron interfacing (after Terial Magic) to the back of the 44" Block. Piece the interfacing to get the size needed. Over lap the pieced sections by 1/2". The interfacing may be slightly smaller than the fabric blocks & it will shrink when you iron it. Lightly spray with water to activate the adhesive. Smooth the interfacing with your hands (this will help to displace the air between the interfacing & fabric).

Start pressing in the center and work out slowly. Iron with steam, the interfacing to the fabric. All edges should be sealed together. If you see air bubbles, spray with water and iron again. Watch my Fabric Prep video for a demo.

([www.claudiascreationsaz.com](http://www.claudiascreationsaz.com) / Videos / Fabric Prep or YouTube / claudiascreationsaz / Fabric Prep)

## Cutting Instructions

### Background Fabric: (3 1/2 yards)

Cut (3) 20" x 44"+/- (or width of Fabric) **Strips**  
 Set (1) aside 20" x 44"+/- strip this is the **Center Block**

### Sub Cut the (2) remaining strips in half:"

Cut (4) 20" wide x 22" height+/- sections these are the **Embroidery Blocks**

### Sub Cut the remaining length of fabric in half lengthwise for the Borders:

Cut (2) 22"+/- wide x 66"+/- length **Top & Bottom** and **Left & Right Side** Border pieces

**More cutting information is on page #94.**

<b>126"</b>			
<b>Center Block</b> <small>20" x Width of Fabric (44"+/-)</small>	<b>Embroidery Block</b> 20" x 22"+/-	<b>Embroidery Block</b> 20" x 22"+/-	<b>Top &amp; Bottom Borders</b> 22" +/- wide x 66"+/- length
	<b>Embroidery Block</b> 20" x 22"+/-	<b>Embroidery Block</b> 20" x 22"+/-	<b>Side Borders</b> 22" +/- wide x 66"+/- length



## Marking the Fabric:

Mark on the front side of the fabric (with removable marker):  
 a **horizontal & vertical line, centered on the fabric block/strip.** (aka=Center Crosshair)

**See my demo on YouTube.** YouTube / ClaudiasCreationsaz / Marking the Fabric  
 (be sure to subscribe & click on the bell to be notified of new videos)

### Read all before marking:

Place the upper right corner of the square ruler in the center of the fabric. See diagram. Draw a line across the top and down the right side of the ruler. This gives you a perfect 90° angle. Extend lines from there. Add all lines needed.

### Center Block

Lay the 6x24 ruler to the right of the square ruler & align the top edges.  
 Draw the length of the rulers. (see red arrow pointing down **Example 1.**)

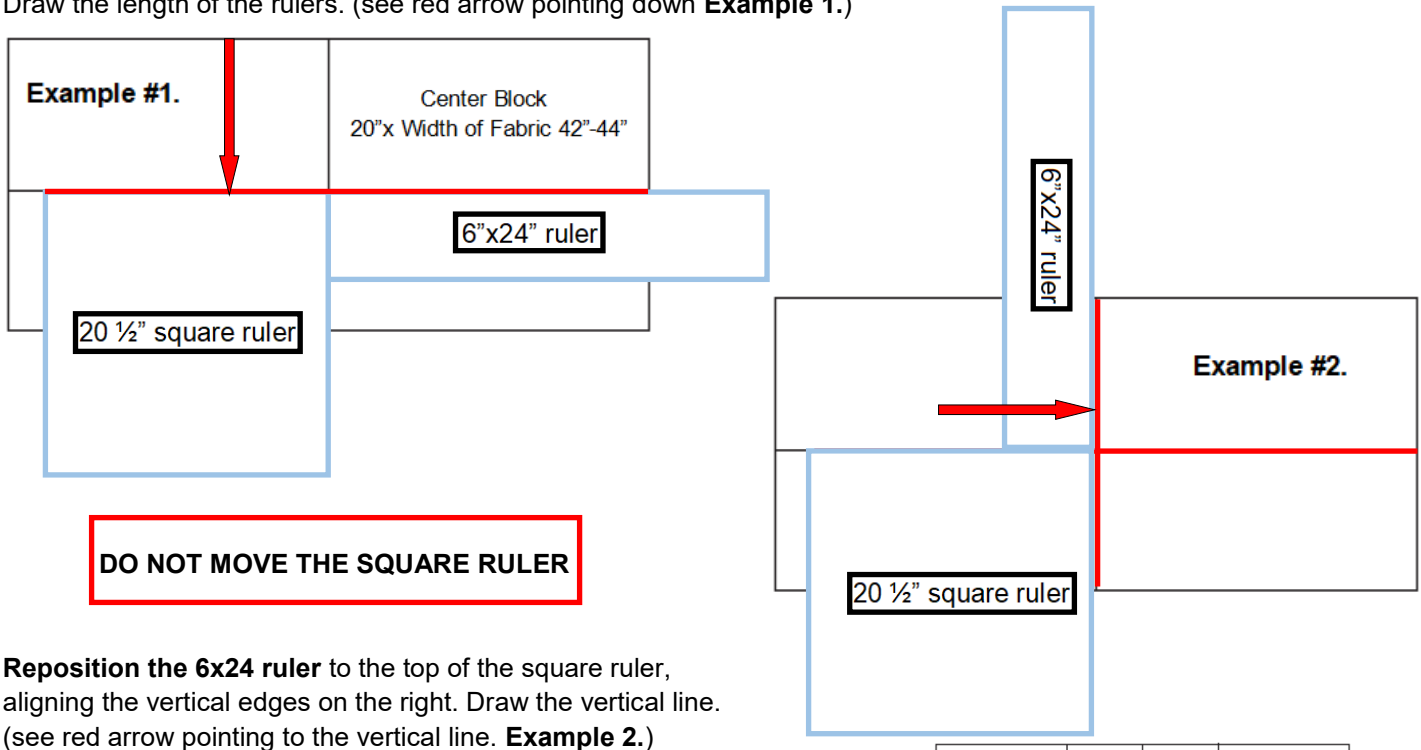

**Reposition the 6x24 ruler** to the top of the square ruler, aligning the vertical edges on the right. Draw the vertical line.  
 (see red arrow pointing to the vertical line. **Example 2.**)

Add an additional **Vertical Line 8"** on either side of Center.  
**Write Top** at the top of the Block.

---

### Embroidery Blocks: (4 20"wide x 22" height+/- )

Mark a **Center Crosshair** on all (4) Blocks.  
 See **Example #3.**  
 Mark additional **Vertical lines 2"** on either side of Center.

Write **Top** at the top of each Block.  
 See **Example #4.**

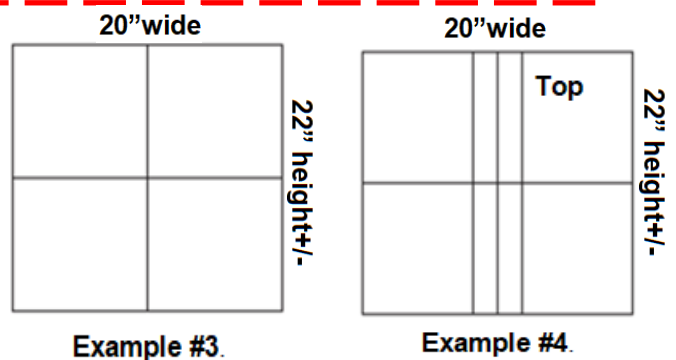

# CHRISTMAS VERSION



(This is my original quilt and since then some designs on this quilt have been enhanced/modified!)

Copyright © Copyright 2021 Claudia Dinnell

No part of this may be reproduced in any form or by any means without written permission from the copyright holder. These designs and instructions are for personal non-commercial use by the original purchaser only and are protected under US & International Laws.

[www.claudiascreationsaz.com](http://www.claudiascreationsaz.com)



# CHRISTMAS VERSION

## Top Row / Christmas Folder / Tree Trimming Block



Cut Block 16 1/2" x 8 1/2"  
Finished Block 16"x8"

# 1 Top Row Folder / Christmas Folder / Tree Trimming Folder / Hooping #1

Select the prepared Background Fabric block with additional lines. Select folder with the format your machine reads. Attach the hoop and the grid (no fabric) to the module.

## Open #1 Sled

**Step #1** Advance to the **embroidery sewing screen** to go to the 1<sup>st</sup> stitch of the design.

**Step #2** Lower the needle, lay an arrow shaped post it note on the grid with the tip of the arrow touching the needle. (The arrow is positioned about 2" to the LEFT & just ABOVE center on the grid).

Top of the Fabric

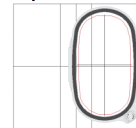

**Fabric Position:** To hoop this design position the **Top of the Fabric** is at the top of the hoop. See **Example #1** below for **1st stitch** position.

Hoop the fabric with the **arrow on the grid pointing 2" to the RIGHT of the Center Crosshair on the FABR**. See **Example #1**. The drawn lines on the fabric must be parallel and perpendicular to the lines on the grid. Remove the grid from the hoop and attach the hoop to the module. **Float stabilizer** (sprayed with 505) **under the attached hoop**.

No Thread, Color #1 **Placement Line**. The needle is positioned **2" to the RIGHT of the Center Crosshair** on the fabric.

See green start arrow in **Example #1**. Sew Color #1 without thread.

**How to sew without thread:** use the **Broken Thread** or **Advance Stitch** icon!! See **Tips for Successful Embroidery**.

It sews from the start arrow, to the right following the drawn line, to the end arrow. Reposition if needed to follow the line.

Add a basting box, sew it out & then turn it off. Advance to **Color #2**.

Thread Color #2 **Emerald (5510) # \_\_\_\_\_**

Embroider the tree, box, & light bulb.

Thread Color #3 **Muslin (0870) # \_\_\_\_\_**

Embroider the snowman and snow on boxes.

Thread Color #4 **Caribbean Blue (4010) # \_\_\_\_\_**

Embroider the boxes, light bulb, & knit hat.

Thread Color #5 **Wildfire (1800) # \_\_\_\_\_**

Embroider the scarf, sled and trim on boxes.

Thread Color #6 **Candlelight (0811) # \_\_\_\_\_**

Embroider the light bulb, inside of box and box handles.

Thread Color #7 **Bright Mint (5610) # \_\_\_\_\_**

Embroider the left tree and hat.

Thread Color #8 **Very Berry (2721) # \_\_\_\_\_**

Embroider the light bulb.

Thread Color #9 **Yellowgreen (6043) # \_\_\_\_\_**

Embroider the skinny tree.

Thread Color #10 **Sterling (0142) # \_\_\_\_\_**

Embroider tops of the light bulbs and squirrels.

Thread Color #11 **Bright Green (5324) # \_\_\_\_\_**

Embroider the shortest tree.

Thread Color #12 **Nutmeg (0932) # \_\_\_\_\_**

Embroider the arms, nut and squirrel tails.

Thread Color #13 **Sterling (again) (0142) # \_\_\_\_\_**

Embroider the highlights on the squirrels.

Thread Color #14 **Red Pepper (1304) # \_\_\_\_\_**

Embroider the nose and light bulb.

Thread Color #15 **Nutmeg (again) (0932) # \_\_\_\_\_**

Embroider the shading on the squirrel body.

Thread Color #16 **Black (0020) # \_\_\_\_\_**

Embroider the outlining, snowflakes & mountains.

Remove the hoop from the module and the fabric from the hoop.

Gently remove the stabilizer & basting stitches from the back.



Top of the Fabric

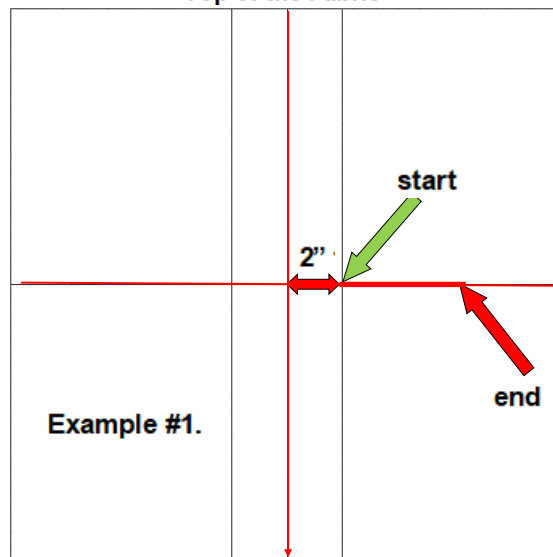

Top of the Fabric

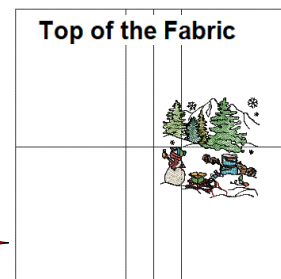

# 1 Top Row Folder / Christmas Folder / Tree Trimming Folder / Hooping #2

Attach the hoop and the grid (no fabric) to the module.

## Open #2 Box

**Step #1** Advance to the **embroidery sewing screen** to go to the 1<sup>st</sup> stitch of the design.

**Step #2** Lower the needle, lay an arrow shaped post it note on the grid with the tip of the arrow touching the needle. (The arrow is positioned about 3" to the RIGHT & just BELOW center on the grid).

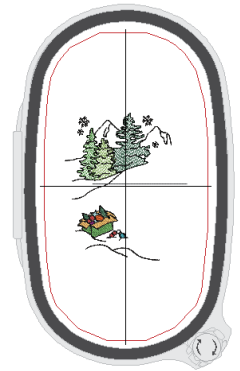

**Fabric Position:** To hoop this design position the **Top of the Fabric** at the top of the hoop. See **Example #2** below for **1st stitch** position.

Top of the Fabric

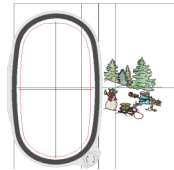

Hoop the fabric with the **arrow on the grid pointing to the Crosshair 2" to the LEFT of Center on the fabric.**

See **Example #2**. The drawn lines on the fabric must be parallel and perpendicular to the lines on the grid.

Remove the grid from the hoop and attach the hoop to the module.

**Float tear away stabilizer** (sprayed with 505) **under the attached hoop, MANDATORY!**

No Thread, Color #1 **Placement Line**. The needle is positioned **2" to the LEFT of Center on the fabric.** See green start arrow in **Example #2**. Sew Color #1 without thread. It sews from the start arrow, to the left following the drawn line, to the end arrow. Reposition if needed. Add a basting box, sew it out then turn it off. Advance to **Color #2**.

Thread Color #2 **Candlelight (0811) # \_\_\_\_\_**  
Embroider the inside of the box.

Thread Color #3 **Bright Green (5324) # \_\_\_\_\_**  
Embroider the tree on the right & decorations in the box.

Thread Color #4 **Caribbean Blue (4010) # \_\_\_\_\_**  
Embroider the light bulb.

Thread Color #5 **Bright Mint (5610) # \_\_\_\_\_**  
Embroider the tree in the middle.

Thread Color #6 **Very Berry (2721) # \_\_\_\_\_**  
Embroider the ornament in the box.

Thread Color #7 **Emerald (5510) # \_\_\_\_\_**  
Embroider the left tree and outer area of the box.

Thread Color #8 **Red Pepper (1304) # \_\_\_\_\_**  
Embroider an ornament.

Thread Color #9 **Spearmint (4240) # \_\_\_\_\_**  
Embroider the stars in the box.

Thread Color #10 **Wildfire (1800) # \_\_\_\_\_**  
Embroider the ornaments.

Thread Color #11 **Sterling (0142) # \_\_\_\_\_**  
Embroider the top of ornaments.

Thread Color #12 **Black (0020) # \_\_\_\_\_**  
Embroider the outlining, snowflakes & mountains.

Remove the hoop from the module and the fabric from the hoop.

Gently remove the stabilizer & basting stitches from the back.



Top of the Fabric

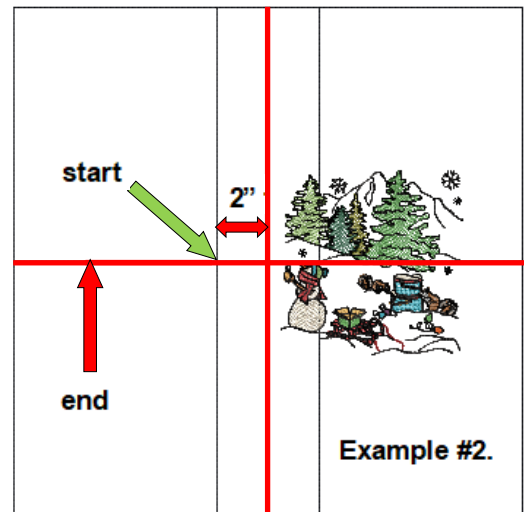

Example #2.

Top of the Fabric

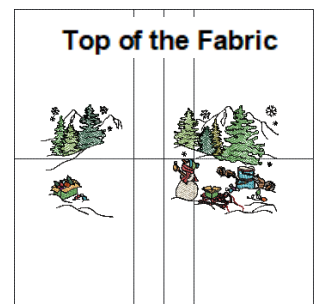



# 1 Top Row Folder / Christmas Folder / Tree Trimming Folder/ Hooping #3

Attach the hoop and the grid (no fabric) to the module.

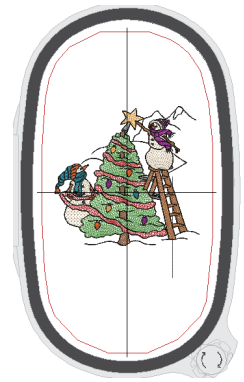

## Open #3 Tree Trimming

**Step #1** Advance to the **embroidery sewing screen** to go to the 1<sup>st</sup> stitch of the design.

**Step #2** Lower the needle, lay an arrow shaped post it note on the grid with the tip of the arrow touching the needle. (The arrow is positioned about 2 ¼" to the RIGHT & slightly above center on the grid).

**Fabric Position:** To hoop this design position the **Top of the Fabric** at the top of the hoop. See **Example #3** below for **1st stitch** position.

Top of the Fabric

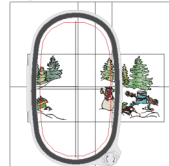

Hoop the fabric with the **arrow on the grid pointing to the Center Crosshair on the fabric.**

See **Example #3**. The drawn lines on the fabric must be parallel and perpendicular to the lines on the grid.

Remove the grid from the hoop and attach the hoop to the module.

**Float tear away stabilizer** (sprayed with 505) **under the attached hoop, MANDATORY!**

No Thread, Color #1 **Placement Line**. The needle is positioned **over the Center Crosshair on the fabric**. See green start arrow in **Example #3**. Sew Color #1 without thread. It sews from the start arrow, downward following the drawn line, to the end arrow. Reposition if needed to follow the line. Add a basting box, sew it out then turn it off. Advance to **Color #2**.

Thread Color #2 **Emerald (5510) # \_\_\_\_\_**  
Embroider the Christmas tree.

Thread Color #3 **Wildfire (1800) # \_\_\_\_\_**  
Embroider the garland.

Thread Color #4 **Muslin (0870) # \_\_\_\_\_**  
Embroider the snowmen.

Thread Color #5 **Very Berry (2721) # \_\_\_\_\_**  
Embroider the scarf, hat and light bulbs.

Thread Color #6 **Red Pepper (1304) # \_\_\_\_\_**  
Embroider the noses, hat trim, and light bulbs.

Thread Color #7 **Dark Teal (4116) # \_\_\_\_\_**  
Embroider the scarf and hat, light bulb and post for star.

Thread Color #8 **Sterling (0142) # \_\_\_\_\_**  
Embroider top of ornaments, base of star & tray on ladder.

Thread Color #9 **Nutmeg (0932) # \_\_\_\_\_**  
Embroider the ladder and snowman arms.

Thread Color #10 **Candlelight (0811) # \_\_\_\_\_**  
Embroider the star and light bulbs.

Thread Color #11 **Pony (1233) # \_\_\_\_\_**  
Embroider the tree trunk.

Thread Color #12 **Black (0020) # \_\_\_\_\_**  
Embroider the outlining & mountains.

Remove the hoop from the module and the fabric from the hoop.

Gently remove the stabilizer & basting stitches from the back. 

Top of the Fabric

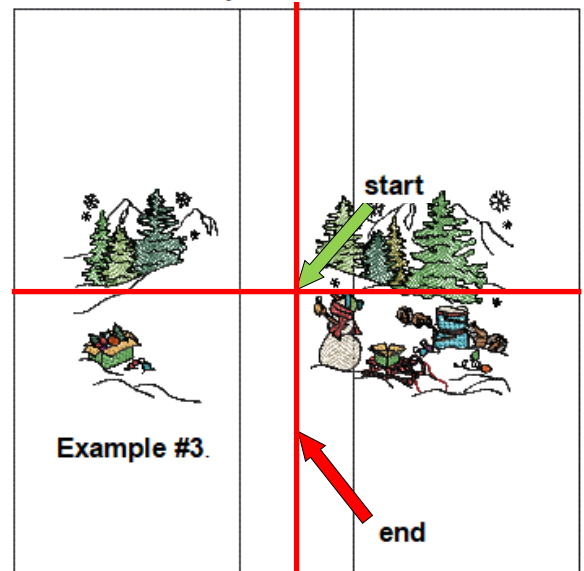

Top of the Fabric



# CHRISTMAS VERSION

## Top Row / Christmas Folder / Snow Angels



Cut Block 13" x 8 1/2"  
Finished Block 12 1/2" x 8"

# 1 Top Row / Christmas Folder / Snow Angels Folder / Hooping #1



Select the prepared 20" x 20" Background Fabric.  
 Select the folder with the format your machine reads.

Attach the hoop and the grid (no fabric) to the module.

## Open #1 Snow Angels

**Step #1** Advance to the **embroidery sewing screen** to go to the 1<sup>st</sup> stitch of the design.  
**Step #2** Lower the needle, lay an arrow shaped post it note on the grid with the tip of the arrow touching the needle. (The arrow is positioned slightly to the LEFT and 2 1/2" below center on the grid).

(Refer to "Tips for Successful Embroidery" about getting to the 1st stitch of the design for **Brother, Babylock, & Janome** machines)

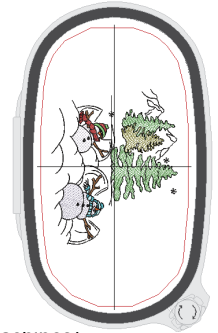

**Fabric Position:** To hoop this design the **Top of the Fabric** is rotated to the **RIGHT** of the hoop.

See **Example #1** below for 1st stitch position.

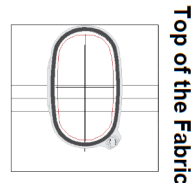

Hoop the fabric with the **arrow on the grid pointing to the Center Crosshair on the FABRIC**.  
 See **Example #1**. The drawn lines on the fabric must be parallel and perpendicular to the lines on the grid.  
 Remove the grid from the hoop and attach the hoop to the module.

**Float tear away stabilizer** (sprayed with 505) **under the attached hoop, MANDATORY!**

No Thread, Color #1 **Placement Line**. The needle is positioned over the Center Crosshair **on the fabric**. See green start arrow in **Example #1**. Sew Color #1 without thread.

**How to sew without thread:** use the **Broken Thread or Advance Stitch icon!!** See **Tips for Successful Embroidery**.  
 It sews from the start arrow, upward following the drawn line, to the end arrow. Reposition if needed to follow the line.

Add a basting box, sew it out, then turn it off.

Advance to **Color #2**.

Thread Color #2 **Muslin (0870) # \_\_\_\_\_**  
 Embroider the snowmen.

Thread Color #3 **Yellowgreen (6043) # \_\_\_\_\_**  
 Embroider the center tree.

Thread Color #4 **Caribbean Blue (4010) # \_\_\_\_\_**  
 Embroider the scarf and hat for the snowman.

Thread Color #5 **Emerald (5510) # \_\_\_\_\_**  
 Embroider the remaining trees & hat trim.

Thread Color #6 **Spearmint (4240) # \_\_\_\_\_**  
 Embroider the remaining pieces of the scarf & hat.

Thread Color #7 **Nutmeg (0932) # \_\_\_\_\_**  
 Embroider the arms.

Thread Color #8 **Wildfire (1800) # \_\_\_\_\_**  
 Embroider the scarf and hat for the remaining snowman.

Thread Color #9 **Red Pepper (1304) # \_\_\_\_\_**  
 Embroider the nose.

Thread Color #10 **Black (0020) # \_\_\_\_\_**  
 Embroider the outlining, mountains and snowflakes.

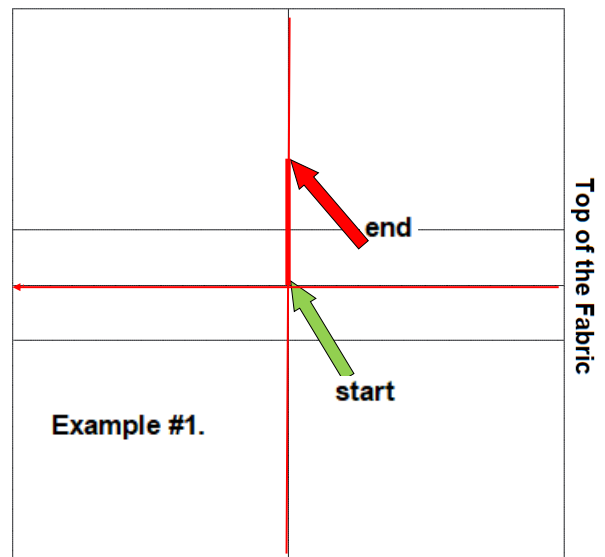

Remove the hoop from the module and the fabric from the hoop.  
 Gently remove the stabilizer & basting stitches from the back.

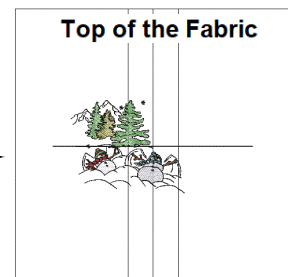



# 1 Top Row Folder / Christmas Folder/ Snow Angel Folder / Hooping #2



Attach the hoop and the grid (no fabric) to the module.

## Open #2 Cardinals

**Step #1** Advance to the **embroidery sewing screen** to go to the 1<sup>st</sup> stitch of the design.

**Step #2** Lower the needle, lay an arrow shaped post it note on the grid with the tip of the arrow touching the needle. (The arrow is positioned about 2 1/2" to the LEFT center on the grid).

**Fabric Position:** To hoop this design the **Top of the Fabric** is positioned at the top of the hoop.

See **Example #2** below for 1st stitch position.

Top of the Fabric

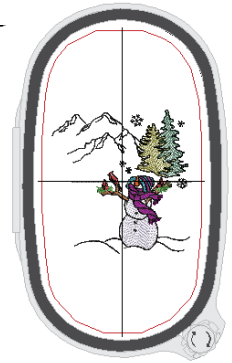
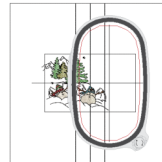

Hoop the fabric with the **arrow on the grid pointing to the Center Crosshair on the FABRIC.**

See **Example #2.** The drawn lines on the fabric must be parallel and perpendicular to the lines on the grid.

Remove the grid, attach the hoop to the module. **Float tear away stabilizer** (sprayed with 505) **under the attached hoop.**

No Thread, Color #1 **Placement Line.** The needle is positioned over the Center Crosshair **on the fabric.** See green start arrow in **Example #2.** Sew Color #1 without thread.

**How to sew without thread:** use the **Broken Thread** or **Advance Stitch** icon!! See **Tips for Successful Embroidery #6** page #4.

It sews from the start arrow, to the right following the drawn line, to the end arrow. Reposition if needed to follow the line. Add a basting box, sew it out then turn it off. Advance to **Color #2.**

Thread Color #2 **Muslin (0870) #** \_\_\_\_\_  
Embroider the snowman.

Thread Color #3 **Yellowgreen (6043) #** \_\_\_\_\_  
Embroider the left tree.

Thread Color #4 **Very Berry (2721) #** \_\_\_\_\_  
Embroider the scarf and hat stripes.

Thread Color #5 **Bright Green (5324) #** \_\_\_\_\_  
Embroider the right tree.

Thread Color #6 **Caribbean Blue (4010) #** \_\_\_\_\_  
Embroider the hat stripes.

Thread Color #7 **Nutmeg (0932) #** \_\_\_\_\_  
Embroider the arms.

Thread Color #8 **Wildfire (1800) #** \_\_\_\_\_  
Embroider the cardinals.

Thread Color #9 **Candlelight (0811) #** \_\_\_\_\_  
Embroider the beaks.

Thread Color #10 **Red Pepper (1304) #** \_\_\_\_\_  
Embroider the nose.

Thread Color #11 **Black (0020) #** \_\_\_\_\_  
Embroider the outlining, mountains & snowflakes.

Thread Color #12 **Emerald (5510) #** \_\_\_\_\_  
Embroider the greenery.

Remove the hoop from the module and the fabric from the hoop.  
Gently remove the stabilizer & basting stitches from the back.



Top of the Fabric

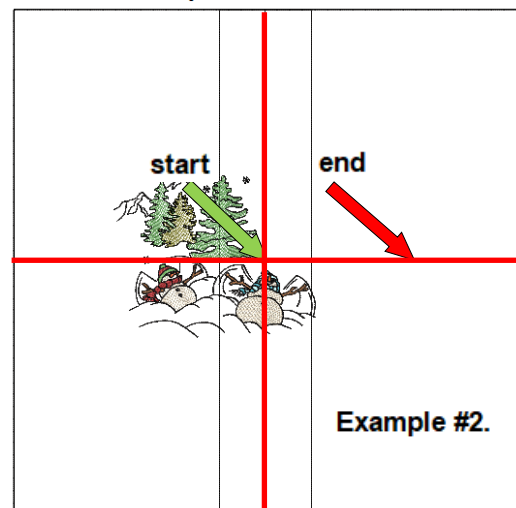

Top of the Fabric



# CHRISTMAS VERSION

## Middle Row

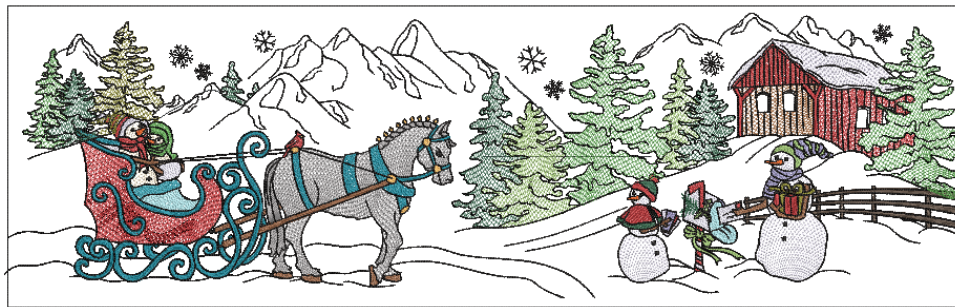
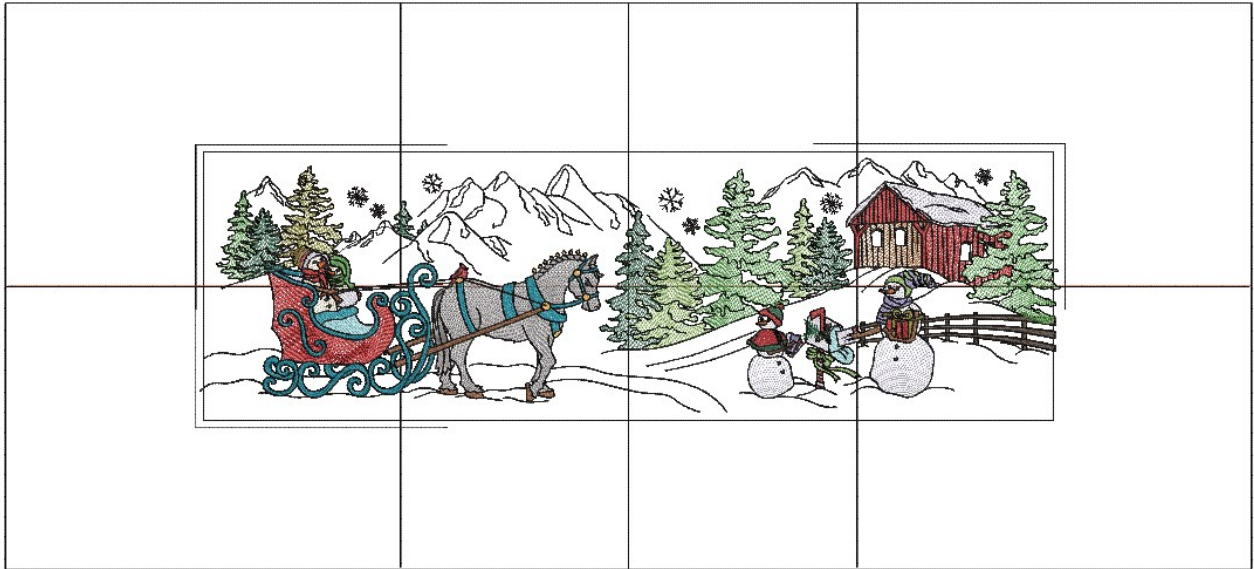

Cut Block 30 1/2" x 9 1/2"  
Finished Block 30" x 9"

## 2 Middle Row / Christmas Folder / Hooping #1

Select the prepared 42" x 20" Background Fabric.  
 Select the folder with the format your machine reads.

Attach the hoop and the grid (no fabric) to the module.

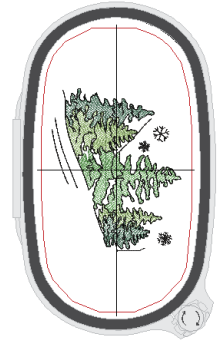

### Open #1 Center Trees

**Step #1** Advance to the **embroidery sewing screen** to go to the 1<sup>st</sup> stitch of the design.

**Step #2** Lower the needle, lay an arrow shaped post it note on the grid with the tip of the arrow touching the needle. (The arrow is positioned just to left and about 3/4" ABOVE center on the grid).

**Fabric Position:** To hoop this design the **Top of the Fabric** is rotated to the **RIGHT** of the hoop.

See **Example #1** below for 1<sup>st</sup> stitch position.

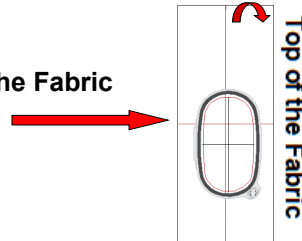

Hoop the fabric with the **arrow on the grid pointing to the crosshair on the FABRIC**.

See **Example #1**. The drawn lines on the fabric must be parallel and perpendicular to the lines on the grid. Remove the grid from the hoop and attach the hoop to the module.

**Float tear away stabilizer** (sprayed with 505) **under the attached hoop**.

Add a basting box, sew it out then turn it off.

### No Thread, Color #1 Placement Line.

The needle is positioned over the center crosshair **on the fabric**.

See green start arrow in **Example #1**. Sew Color #1 without thread.

**How to sew without thread: use the Broken Thread or Advance Stitch icon!!**

See **Tips for Successful Embroidery**.

It sews downward 8" following the drawn line. Reposition if needed.

Advance to **Color #2**.

Thread Color #2 **Emerald (5510) # \_\_\_\_\_**

Embroider the center tree.

Thread Color #3 **Bright Green (5324) # \_\_\_\_\_**

Embroider the outside trees.

Thread Color #4 **Bright Mint (5610) # \_\_\_\_\_**

Embroider the inside trees.

Thread Color #5 **Black (0020) # \_\_\_\_\_**

Embroider the outlining and snowflakes and the Placement Line for next hooping.

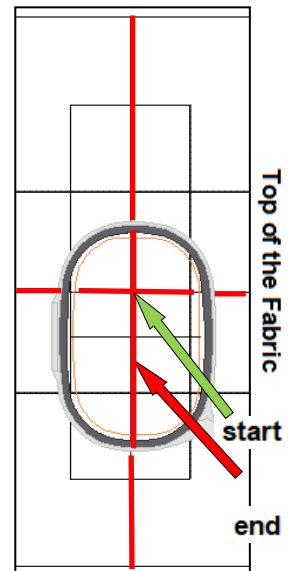

**Example #1.**

Remove the hoop from the module and the fabric from the hoop.

Gently remove the stabilizer & basting stitches from the back.

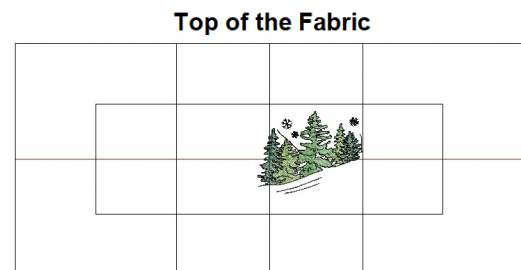



## 2 Middle Row / Christmas Folder / Hooping #2

Attach the hoop and the grid (no fabric) to the module.

Larger Hoops may be able to combine Hoopings #2 & #3 together

### Open #2 Barn

**Step #1** Advance to the **embroidery sewing screen** to go to the 1<sup>st</sup> stitch of the design.

**Step #2** Lower the needle, lay an arrow shaped post it note on the grid with the tip of the arrow touching the needle. (The arrow is positioned about 1" to left and 3 1/4" ABOVE center on the grid).

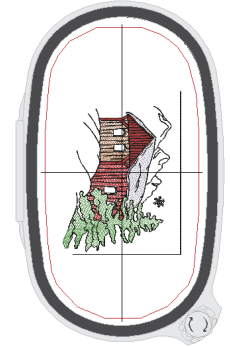

**Fabric Position:** To hoop this design the **Top of the Fabric** is rotated to the **RIGHT** of the hoop.

See **Example #2** below for 1st stitch position.

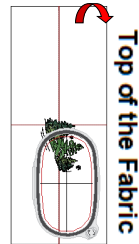

Hoop the fabric with the **arrow on the grid pointing to the green start arrow**. See **Example #2**. The drawn lines on the fabric must be parallel and perpendicular to the lines on the grid. Remove the grid from the hoop and attach the hoop to the module.

**Float tear away stabilizer** (sprayed with 505) **under the attached hoop**.

### No Thread, Color #1 Placement Line.

The needle is positioned at the green start arrow.

See green start arrow in **Example #2**.

Sew Color #1 without thread.

**How to sew without thread: use the Broken Thread or Advance Stitch icon!!**

See **Tips for Successful Embroidery**.

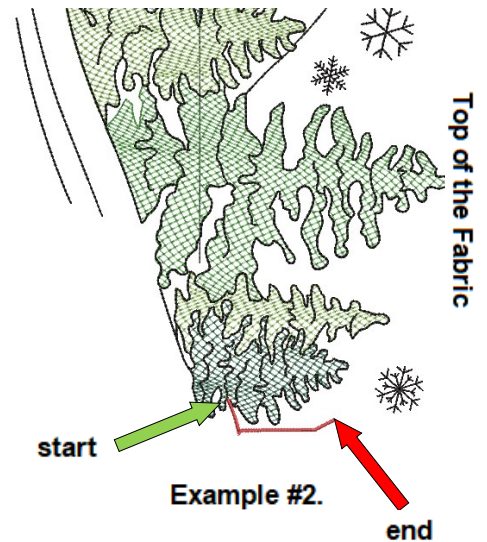

It sews from the start to the end arrow following the stitched in black line.

(Placement line shown in red). Reposition if needed.

Add a basting box, sew it out then turn it off.

Advance to **Color #2**.

Thread Color #2 **Nutmeg (0932)** # \_\_\_\_\_

Embroider the inside of the barn.

Thread Color #3 **Wildfire (1800)** # \_\_\_\_\_

Embroider the outside of the barn.

Thread Color #4 **Muslin (0870)** # \_\_\_\_\_

Embroider the snow on the roof.

Thread Color #5 **Emerald (5510)** # \_\_\_\_\_

Embroider the tree.

Thread Color #6 **Black (0020)** # \_\_\_\_\_

Embroider the outlining, snowflakes and

**"corner placement lines"**.

**(Do not remove the corner placement lines yet.**

**Be careful when removing the stabilizer.)**

Remove the hoop from the module

and the fabric from the hoop.

Gently remove the stabilizer & basting stitches from the back.

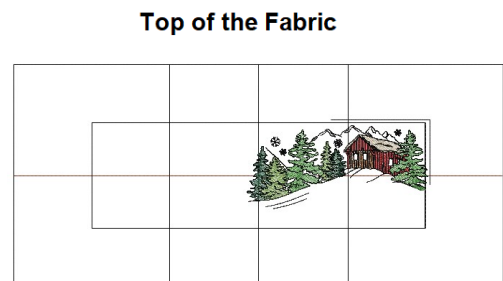
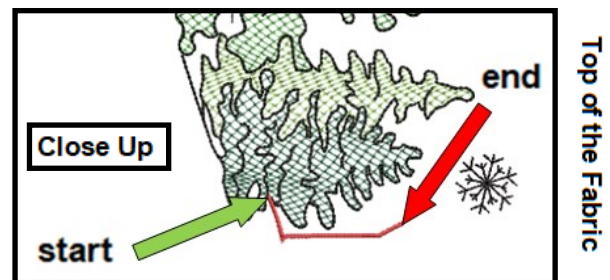

## 2 Middle Row/ Christmas Folder / Hooping #3

Attach the hoop and the grid (no fabric) to the module.

### Open #3 Snow People

**Step #1** Advance to the **embroidery sewing screen** to go to the 1<sup>st</sup> stitch of the design.

**Step #2** Lower the needle, lay an arrow shaped post it note on the grid with the tip of the arrow touching the needle. (The arrow is positioned about 1 1/4" to **RIGHT** and 2 1/2" **BELOW** center on the grid).

**Fabric Position:** To hoop this design the **Top of the Fabric** is rotated to the **RIGHT** of the hoop. See **Example #3** below for 1st stitch position.

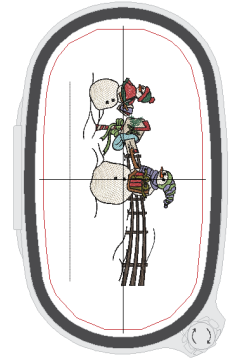
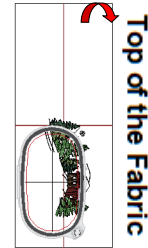

Hoop the fabric with the **arrow on the grid pointing to the green start arrow**.

See **Example #3**. The drawn lines on the fabric must be parallel and perpendicular to the lines on the grid.

Remove the grid. **Float tear away stabilizer** (sprayed with 505) **under the attached hoop**.

### No Thread, Color #1 Placement Line.

The needle is positioned at the green start arrow see **Example #3**. Sew Color #1 without thread.

**How to sew without thread:** use the **Broken Thread** or **Advance Stitch** icon!! See **Tips for Successful Embroidery**.

It sews downward following the stitched in black line.

(Placement Line shown in red). Reposition if needed. Add a basting box, sew it out then turn it off. Advance to **Color #2**.

Thread Color #2 **Chocolate (1876) #** \_\_\_\_\_  
Embroider the fence.

Thread Color #3 **Muslin (0870) #** \_\_\_\_\_  
Embroider the snowmen and mailbox.

Thread Color #4 **Wildfire (1800) #** \_\_\_\_\_  
Embroider the hat, shawl, post and present.

Thread Color #5 **Dawn of Violet (3130) #** \_\_\_\_\_  
Embroider the mother's scarf, hat & letters.

Thread Color #6 **Spearmint (4240) #** \_\_\_\_\_  
Embroider the inside of the mailbox.

Thread Color #7 **Bright Mint (5610) #** \_\_\_\_\_  
Embroider the hat, leaves, and bow.

Thread Color #8 **Bright Green (5324) #** \_\_\_\_\_  
Embroider the hat, shawl, and fern.

Thread Color #9 **Yellowgreen (6043) #** \_\_\_\_\_  
Embroider the ribbon.

Thread Color #10 **Red Pepper (1304) #** \_\_\_\_\_  
Embroider the noses.

Thread Color #11 **Nutmeg (0932) #** \_\_\_\_\_  
Embroider the arms.

Thread Color #12 **Black (0020) #** \_\_\_\_\_  
Embroider the outlining and **placement line**.

Remove the hoop from the module and the fabric from the hoop.

**(Do not remove the straight placement line** under the people yet be careful when removing the stabilizer.)

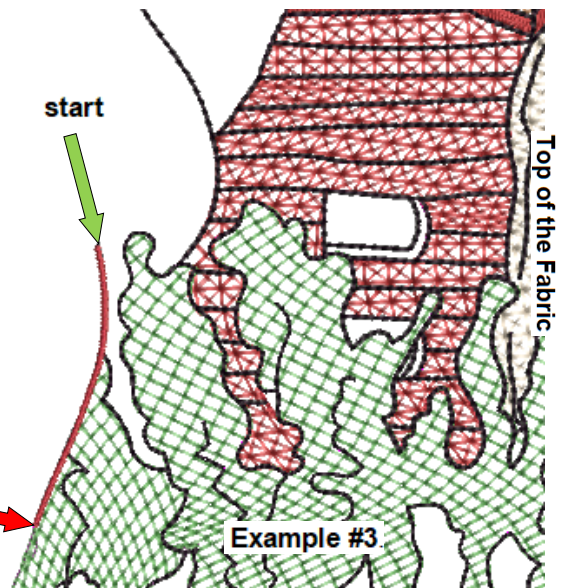

Top of the Fabric

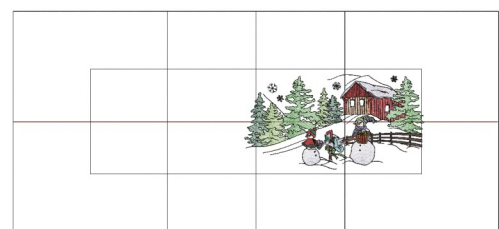

## 2 Middle Row / Christmas Folder / Hooping #4

Attach the hoop and the grid (no fabric) to the module.

### Open #4 Mountains

**Step #1** Advance to the **embroidery sewing screen** to go to the 1<sup>st</sup> stitch of the design.

**Step #2** Lower the needle, lay an arrow shaped post it note on the grid with the tip of the arrow touching the needle. (The arrow is positioned about 1 1/2" to LEFT and 5" BELOW center on the grid).

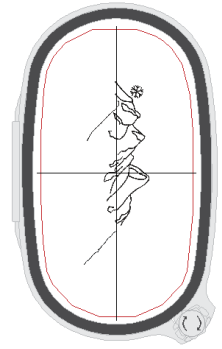

**Fabric Position:** To hoop this design the **Top of the Fabric** is rotated to the **RIGHT** of the hoop.

See **Example #4** below for 1<sup>st</sup> stitch position.

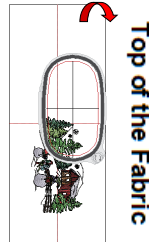

Hoop the fabric with the **arrow on the grid pointing to the green start arrow**.

See **Example #4**. The drawn lines on the fabric must be parallel and perpendicular to the lines on the grid.

Remove the grid from the hoop and attach the hoop to the module.

**Float tear away stabilizer** (sprayed with 505) **under the attached hoop**.

### No Thread, Color #1 Placement Line.

The needle is positioned at the green start arrow see

**Example #4**. Sew Color #1 without thread.

**How to sew without thread:** use the **Broken Thread** or **Advance Stitch** icon!!  
See **Tips for Successful Embroidery**.

It sews from the start to the end arrow following the black stitched in line. (Placement Line shown in red).  
Reposition if needed.

Add a basting box, sew it out then turn it off.

Advance to **Color #2**.

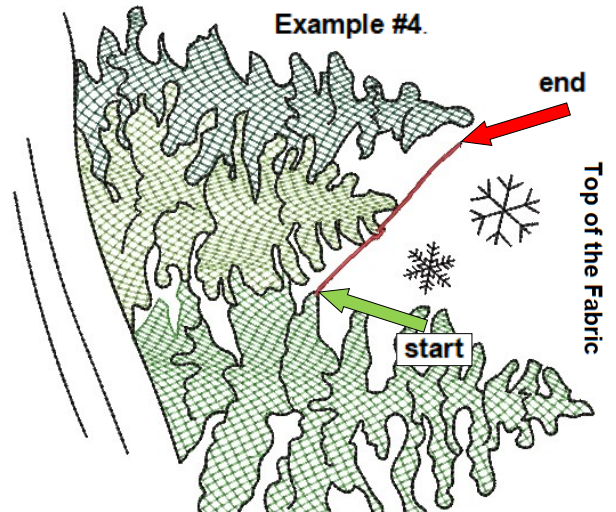

Thread Color #2 **Black (0020) # \_\_\_\_\_**

Embroider the outlining and snowflakes.

Remove the hoop from the module

and the fabric from the hoop.

Gently remove the stabilizer & basting stitches from the back.



**Top of the Fabric**

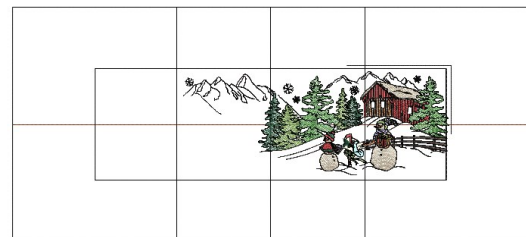

## 2 Middle Row / Christmas Folder / Hooping #5

Attach the hoop and the grid (no fabric) to the module.

### Open #5 Corner Trees

**Step #1** Advance to the **embroidery sewing screen** to go to the 1<sup>st</sup> stitch of the design.

**Step #2** Lower the needle, lay an arrow shaped post it note on the grid with the tip of the arrow touching the needle. (The arrow is positioned about 1 1/2" to LEFT and 5 1/4" BELOW center on the grid).

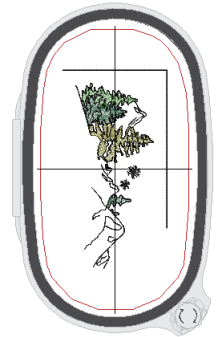

**Fabric Position:** To hoop this design the **Top of the Fabric** is rotated to the **RIGHT** of the hoop.

See **Example #5** below for 1st stitch position.

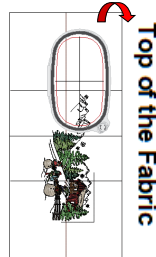

Hoop the fabric with the **arrow on the grid pointing to the green start arrow**.

See **Example #5**. The drawn lines on the fabric must be parallel and perpendicular to the lines on the grid.

Remove the grid from the hoop and attach the hoop to the module.

**Float tear away stabilizer** (sprayed with 505) **under the attached hoop**.

### No Thread, Color #1 Placement Line.

The needle is positioned at the green start arrow see

**Example #5**. Sew Color #1 without thread.

**How to sew without thread: use the Broken Thread or Advance Stitch icon!!**  
See **Tips for Successful Embroidery**.

It sews upward following the stitched in black line  
(Placement Line shown in red).

Add a basting box, sew it out then turn it off.

Reposition if needed. Advance to **Color #2**.

Thread Color #2 **Bright Green (5324) #** \_\_\_\_\_

Embroider two trees.

Thread Color #3 **Yellowgreen (6043) #** \_\_\_\_\_

Embroider the center tree.

Thread Color #4 **Emerald (5510) #** \_\_\_\_\_

Embroider the remaining tree.

Thread Color #5 **Black (0020) #** \_\_\_\_\_

Embroider the outlining, snowflakes and "corner placement lines".

**(Do not remove these lines yet. Be careful removing the stabilizer.)**

Remove the hoop from the module

and the fabric from the hoop.

Gently remove the stabilizer & basting stitches from the back.

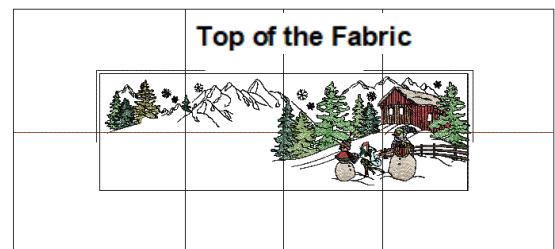
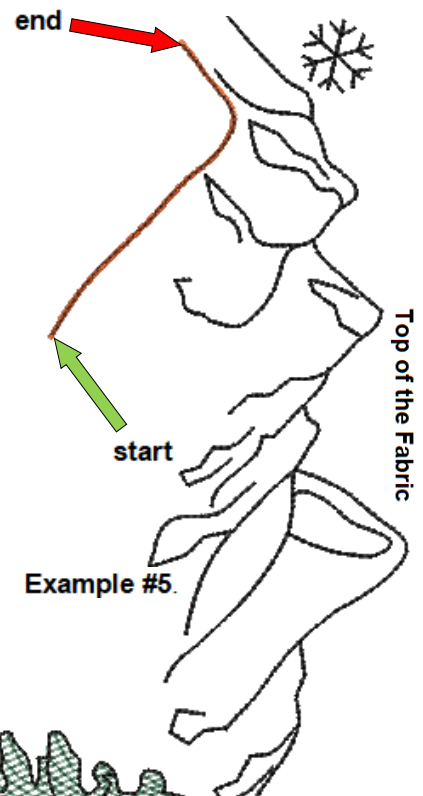



## 2 Middle Row / Christmas Folder / Hooping #6

Attach the hoop and the grid (no fabric) to the module.

### Open #6 Sleigh

**Step #1** Advance to the **embroidery sewing screen** to go to the 1<sup>st</sup> stitch of the design.

**Step #2** Lower the needle, lay an arrow shaped post it note on the grid with the tip of the arrow touching the needle. (The arrow is positioned about 3" to **RIGHT** and 3" **BELOW** center on the grid).

**Fabric Position:** To hoop this design the **Top of the Fabric** is **rotated** to the **RIGHT** of the hoop.

See **Example #6** below for **1st stitch** position.

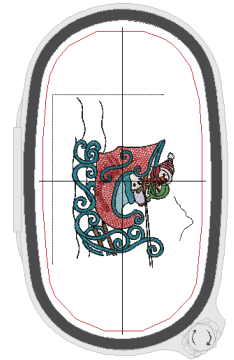

Hoop the fabric with the **arrow on the grid pointing to the green start arrow**. See **Example #6**. The drawn lines on the fabric must be **parallel and perpendicular** to the lines on the grid. Remove the grid from the hoop and attach the hoop to the module. **Float 2 pieces** of tear away stabilizer (sprayed with 505) **under the attached hoop**.

No Thread Color, #1 **Placement Line**.

The needle is positioned at the green start arrow see **Example #6**. Sew Color #1 without thread.

**How to sew without thread:** use the **Broken Thread** or **Advance Stitch** icon!! See **Tips for Successful Embroidery**.

It sews upward following the stitched in black line

Reposition if needed. Add a basting box, sew it out then turn it off. Advance to **Color #2**.

Thread Color #2 **Muslin (0870) # \_\_\_\_\_**

Embroider the snowman (sews over the tree area), stripes on hat and muffler.

Thread Color #3 **Wildfire (1800) # \_\_\_\_\_**

Embroider the hat, scarf and sleigh (sews over tree).

Thread Color #4 **White (0015) # \_\_\_\_\_**

Embroider the hat and muff.

Thread Color #5 **Dark Teal (4116) # \_\_\_\_\_**

Embroider the sleigh runners.

Thread Color #6 **Emerald (5510) # \_\_\_\_\_**

Embroider the head scarf.

Thread Color #7 **Caribbean Blue (4010) # \_\_\_\_\_**

Embroider the top of the blanket.

Thread Color #8 **Spearmint (4240) # \_\_\_\_\_**

Embroider the blanket.

Thread Color #9 **Pony (1233) # \_\_\_\_\_**

Embroider the sleigh bars.

Thread Color #10 **Red Pepper (1304) # \_\_\_\_\_**

Embroider the noses.

Thread Color #11 **Nutmeg (0932) # \_\_\_\_\_**

Embroider the arms.

Thread Color #12 **Black (0020) # \_\_\_\_\_**

Embroider the outlining & **"corner placement lines"**.

**(Do not remove the corner placement lines yet. Be careful when removing the stabilizer.)**

Remove the hoop from the module

and the fabric from the hoop.

Gently remove the stabilizer & basting stitches from the back.

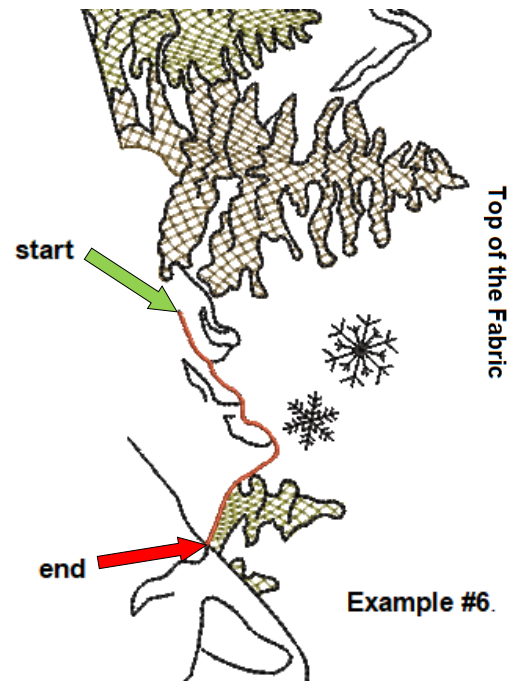

**Example #6.**

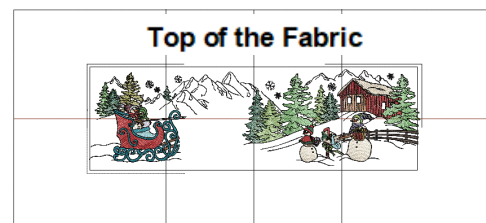

## 2 Middle Row / Christmas Folder / Hooping #7

Attach the hoop and the grid (no fabric) to the module.

### Open #7 Horse

**Step #1** Advance to the **embroidery sewing screen** to go to the 1<sup>st</sup> stitch of the design.

**Step #2** Lower the needle, lay an arrow shaped post it note on the grid with the tip of the arrow touching the needle. (The arrow is positioned about 2" to RIGHT and 5" ABOVE center on the grid).

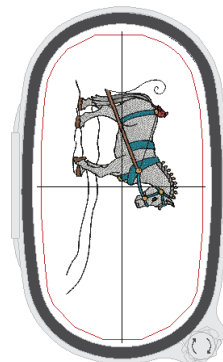

**Fabric Position:** To hoop this design the **Top of the Fabric** is rotated to the **RIGHT** of the hoop.

See **Example #7** below for 1st stitch position.

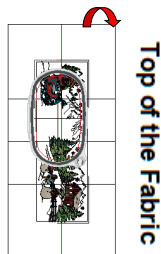

Hoop the fabric with the **arrow on the grid pointing to the green start arrow**. See **Example #7**. The drawn lines on the fabric must be parallel and perpendicular to the lines on the grid. Remove the grid from the hoop and attach the hoop to the module. **Float 2 pieces** of tear away stabilizer (sprayed with 505) **under the attached hoop**.

### No Thread Color, #1 Placement Line.

The needle is positioned at the green start arrow see

**Example #7**. Sew Color #1 without thread.

**How to sew without thread:** use the **Broken Thread** or **Advance Stitch** icon!! See **Tips for Successful Embroidery**.

It sews following the stitched in black line

(Placement Line shown in red) from the start to the end arrow.

Reposition if needed.

Add a basting box, sew it out then turn it off.

Advance to **Color #2**.

Thread Color #2 **Silvery Grey (1972) #** \_\_\_\_\_

Embroider the horse.

Thread Color #3 **Dark Teal (4116) #** \_\_\_\_\_

Embroider the horse hardware.

Thread Color #4 **Candlelight (0811) #** \_\_\_\_\_

Embroider the brass decor for the horse.

Thread Color #5 **Wildfire (1800) #** \_\_\_\_\_

Embroider the bird.

Thread Color #6 **Pony (1233) #** \_\_\_\_\_

Embroider the hoofs and harness.

Thread Color #7 **Black (0020) #** \_\_\_\_\_

Embroider the outlining.

**Example #7.**

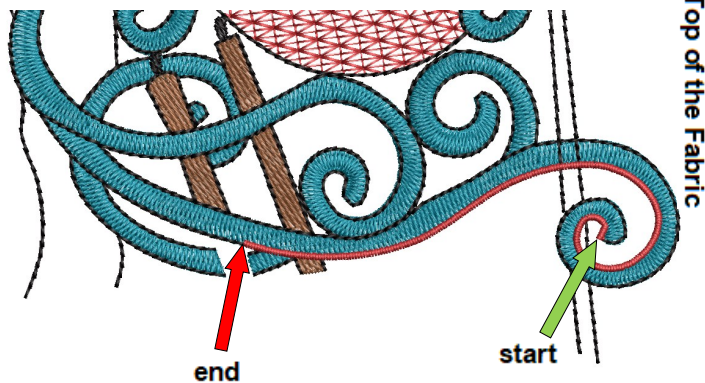

Remove the hoop from the module and the fabric from the hoop.

Gently remove the stabilizer & basting stitches from the back.

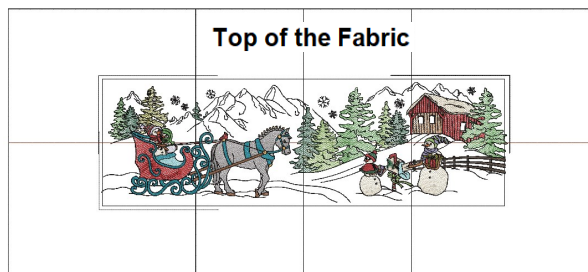

# CHRISTMAS VERSION

## Bottom Row / Christmas Folder / Carolers Block

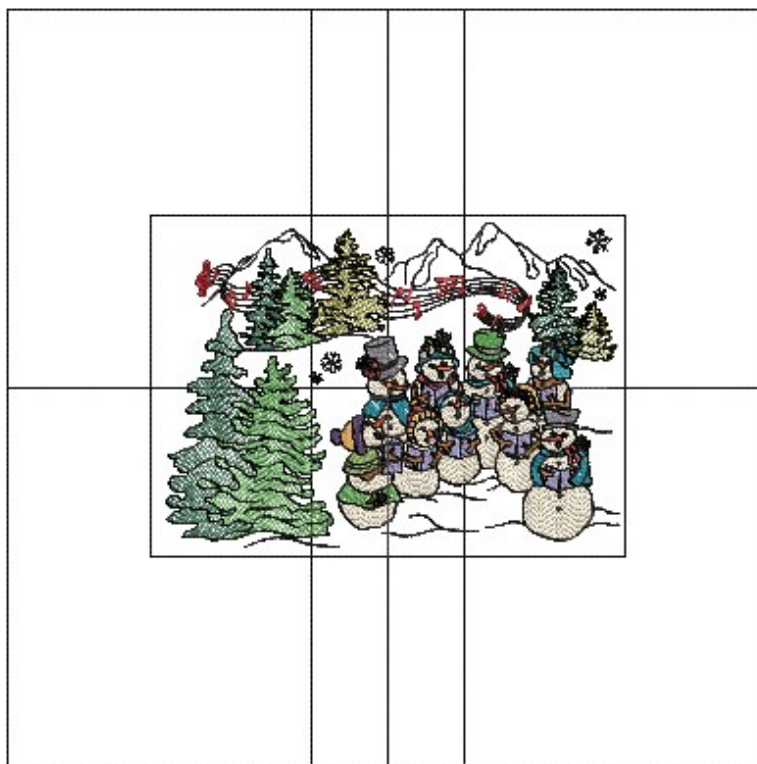

Cut Block 13" x 9 1/2"  
Finished Block 12 1/2" x 9"

### 3 Bottom Row / Christmas Folder / Carolers Block / Hooping #1

Select the prepared 20" x 20" Background Fabric. Select the folder with the format your machine reads. Attach the hoop and the grid (no fabric) to the module.

Larger Hoops may be able to combine Hoopings together

#### Open #1 Music

**Step #1** Advance to the **embroidery sewing screen** to go to the 1<sup>st</sup> stitch of the design.

**Step #2** Lower the needle, lay an arrow shaped post it note on the grid with the tip of the arrow touching the needle. (The arrow is positioned about 2" to the LEFT & 1/2" ABOVE center on the grid).

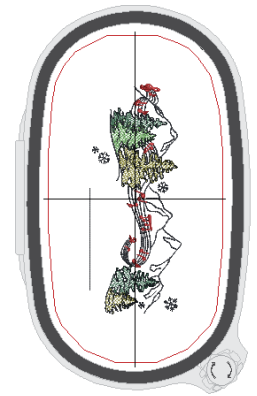

**Fabric Position:** To hoop this design the **Top of the Fabric** is **rotated** to the **RIGHT** of the hoop.

See **Example #1** below for **1st stitch** position.

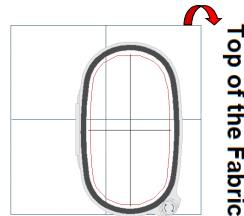

Hoop the fabric with the **arrow on the grid pointing to the Center Crosshair on the FABRIC**.

See **Example #1**. The drawn lines on the fabric must be parallel and perpendicular to the lines on the grid.

Remove the grid from the hoop and attach the hoop to the module.

**Float tear away stabilizer** (sprayed with 505) **under the attached hoop, MANDATORY!**

#### No Thread, Color #1 Placement Line.

The needle is positioned at the Center Crosshair see green start arrow in **Example #1**.

Sew Color #1 without thread.

**How to sew without thread:** use the Broken Thread or Advance Stitch icon!! See Tips for Successful Embroidery.

It sews downward following the drawn line (Placement Line shown in red).  
Add a basting box, sew it out then turn it off.  
Advance to **Color #2**.

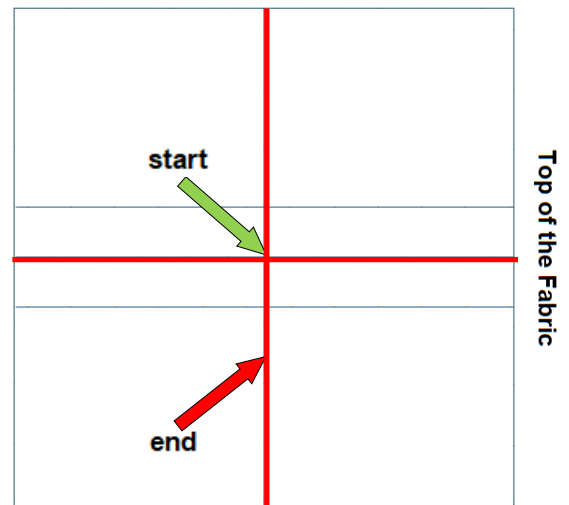

Thread Color #2 **Bright Green (5324) #** \_\_\_\_\_

Embroider two trees.

Thread Color #3 **Emerald (5510) #** \_\_\_\_\_

Embroider one tree.

Thread Color #4 **Yellowgreen (6043) #** \_\_\_\_\_

Embroider two trees.

Thread Color #5 **Black (0020) #** \_\_\_\_\_

Embroider the outlining.

Thread Color #6 **Wildfire (1800) #** \_\_\_\_\_

Embroider the music staff, stanza and notes.

Remove the hoop from the module and the fabric from the hoop.

Gently remove the stabilizer & basting stitches from the back.

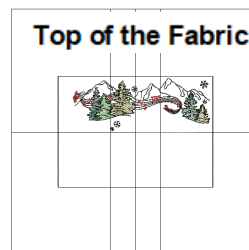



### 3 Bottom Row / Christmas Folder / Carolers Block / Hooping #2

Select the folder with the format your machine reads. Attach the hoop and the grid (no fabric) to the module.

#### Open #2 Trees

**Step #1** Advance to the **embroidery sewing screen** to go to the 1<sup>st</sup> stitch of the design.

**Step #2** Lower the needle, lay an arrow shaped post it note on the grid with the tip of the arrow touching the needle. (The arrow is positioned about 3" to the RIGHT & 1 1/4" ABOVE center on the grid).

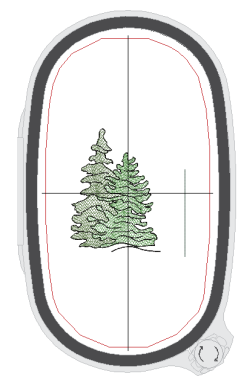

**Fabric Position:** To hoop this design the **Top of the Fabric** is **positioned at the TOP** of the hoop.  
See **Example #2 below** for **1st stitch** position.

Top of the Fabric

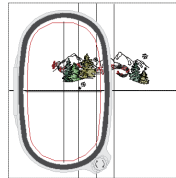

Hoop the fabric with the **arrow on the grid pointing to the Center Crosshair on the FABRIC**.

See **Example #2**. The drawn lines on the fabric must be parallel and perpendicular to the lines on the grid.

Remove the grid from the hoop and attach the hoop to the module.

**Float tear away stabilizer** (sprayed with 505) **under the attached hoop**, **MANDATORY!**

#### No Thread, Color #1 **Placement Line**.

The needle is positioned at the Center Crosshair, see the green start arrow in **Example #2**.

Sew Color #1 without thread.

**How to sew without thread:** use the Broken Thread or Advance Stitch icon!! See **Tips for Successful Embroidery**.

It sews downward about 5" following the drawn line  
Reposition if needed.  
Add a basting box, sew it out then turn it off.  
Advance to **Color #2**.

- Thread Color #2 **Bright Green (5324) # \_\_\_\_\_**  
Embroider the taller tree.
- Thread Color #3 **Emerald (5510) # \_\_\_\_\_**  
Embroider the remaining tree.
- Thread Color #4 **Black (0020) # \_\_\_\_\_**  
Embroider the outlining.

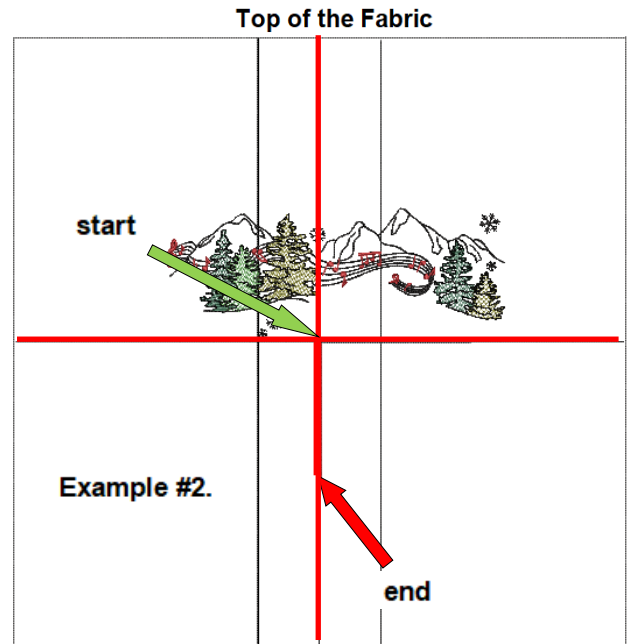

Remove the hoop from the module and the fabric from the hoop. Gently remove the stabilizer & basting stitches from the back.



Top of the Fabric

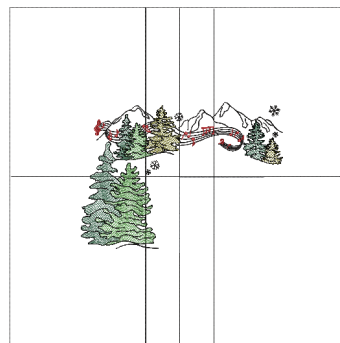

### 3 Bottom Row / Christmas Folder / Carolers Block / Hooping #3

Select the folder with the format your machine reads. Attach the hoop and the grid (no fabric) to the module.

#### Open #3 The Carolers

**Step #1** Advance to the **embroidery sewing screen** to go to the 1<sup>st</sup> stitch of the design.

**Step #2** Lower the needle, lay an arrow shaped post it note on the grid with the tip of the arrow touching the needle. (The arrow is positioned about 1 1/4" to the RIGHT & 2 1/4" ABOVE center on the grid).



**Fabric Position:** To hoop this design the **Top of the Fabric** is **rotated** to the **RIGHT** of the hoop.

See **Example #2** below for **1st stitch** position.

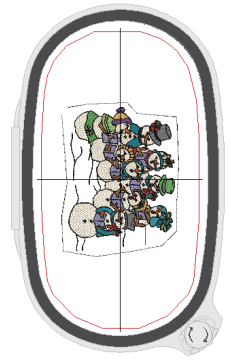
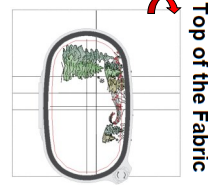

Hoop the fabric with the **arrow on the grid pointing to the center crosshair on the FABRIC**.

See **Example #3**. The drawn lines on the fabric must be parallel and perpendicular to the lines on the grid.

Remove the grid from the hoop and attach the hoop to the module.

**Float tear away stabilizer** (sprayed with 505) **under the attached hoop**, MANDATORY!

No Thread, Color #1 **Placement Line**.

The needle is positioned at the green start arrow see **Example #3**. Sew Color #1 without thread.

**How to sew without thread:** use the **Broken Thread** or **Advance Stitch** icon!! See **Tips for Successful Embroidery**.

It sews downward following the drawn line (Placement Line shown in red).

Add a basting box, sew it out then turn it off. Advance to **Color #2**.

Thread Color #2 **Muslin (0870) #** \_\_\_\_\_

Embroider the snow people

Thread Color #3 **Caribbean Blue (4010) #** \_\_\_\_\_

Embroider the scarves and hats.

Thread Color #4 **Dawn of Violet (3130) #** \_\_\_\_\_

Embroider the song books.

Thread Color #5 **Candlelight (0811) #** \_\_\_\_\_

Embroider the hats.

Thread Color #6 **Grape Jelly (2702) #** \_\_\_\_\_

Embroider the trim and ball on hat.

Thread Color #7 **Emerald (5510) #** \_\_\_\_\_

Embroider the apron and man's hat.

Thread Color #8 **Dark Teal (4116) #** \_\_\_\_\_

Embroider the hat and scarves.

Thread Color #9 **Bright Mint (5610) #** \_\_\_\_\_

Embroider the collar and holly.

Thread Color #10 **Nutmeg (0932) #** \_\_\_\_\_

Embroider the arms.

Thread Color #11 **Red Pepper (1304) #** \_\_\_\_\_

Embroider the noses.

Thread Color #12 **Leadville (0112) #** \_\_\_\_\_

Embroider the hats and hat trim.

Thread Color #13 **Wildfire (1800) #** \_\_\_\_\_

Embroider the berries, bows, hat and trims.

Thread Color #14 **Black (0020) #** \_\_\_\_\_

Embroider the outlining.

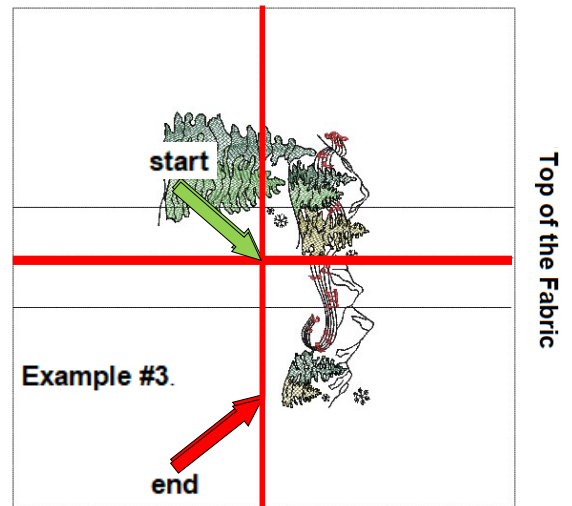

**Top of the Fabric**

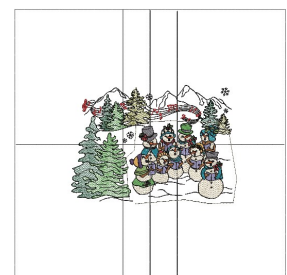

Remove the hoop from the module and the fabric from the hoop.

Gently remove the stabilizer & basting stitches from the back.



# CHRISTMAS VERSION

## Bottom Row/Christmas Folder/Gathering Presents

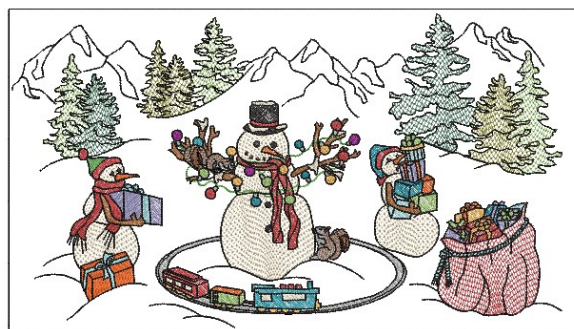
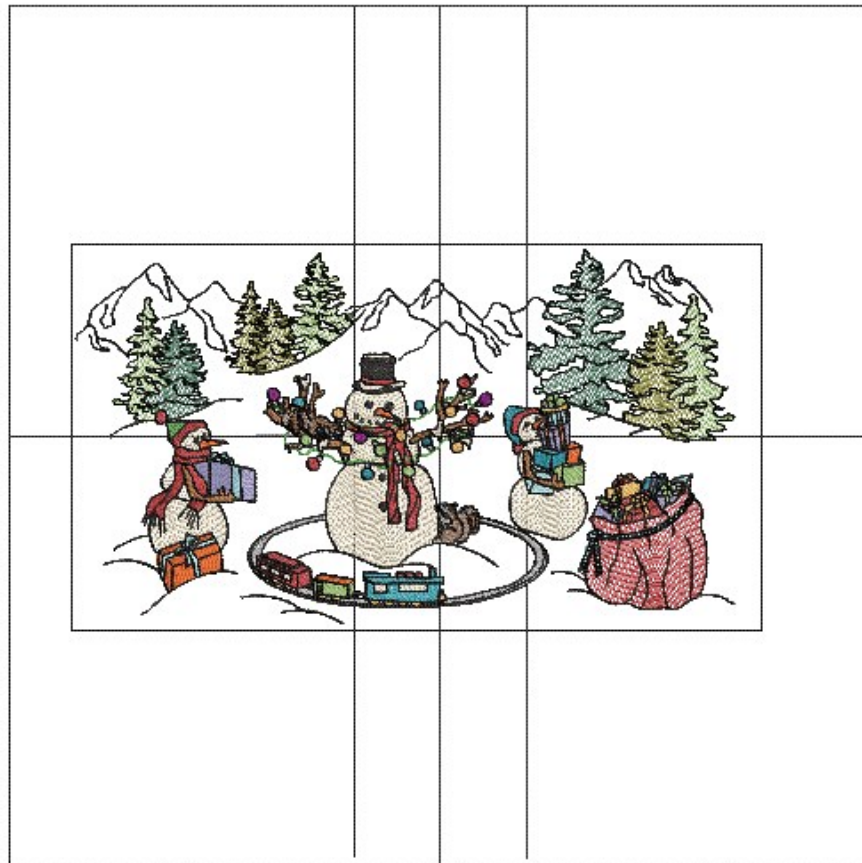

Cut Block 16 1/2" x 9 1/2"  
Finished Block 16" x 9"

### 3 Bottom Row / Christmas Folder / Gathering Presents / Hooping #1

Select the prepared 20" x 20" Background Fabric and the folder with the format your machine reads. Attach the hoop and the grid (no fabric) to the module.

**Larger Hoops may be able to combine Hoopings**

#### Open #1 Sack of Presents

**Step #1** Advance to the **embroidery sewing screen** to go to the 1<sup>st</sup> stitch of the design.

**Step #2** Lower the needle, lay an arrow shaped post it note on the grid with the tip of the arrow touching the needle. (The arrow is positioned about 3 1/2" to the LEFT just BELOW center on the grid).

**Fabric Position:** To hoop this design position the **Top of the Fabric** at the top of the hoop. See **Example #1** below for **1st stitch** position.

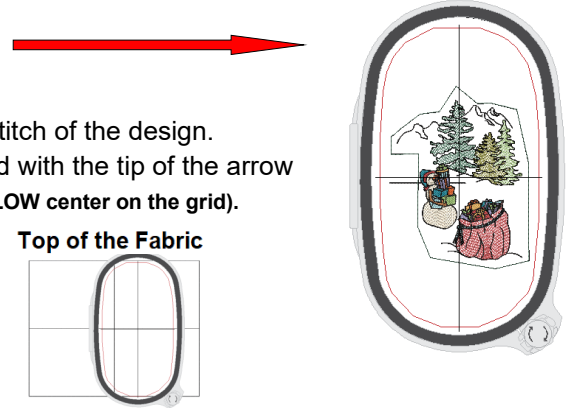

Hoop the fabric with the **arrow on the grid pointing to the Center Crosshair on the FABRIC**. See **Example #1**. The drawn lines on the fabric must be parallel and perpendicular to the lines on the grid. Remove the grid from the hoop and attach the hoop to the module.

**Float tear away stabilizer** (sprayed with 505) **under the attached hoop**, MANDATORY!

No Thread, Color #1 **Placement Line**. The needle is positioned over the Center Crosshair **on the fabric**. See green start arrow in **Example #1**. Sew Color #1 without thread.

It sews from the start arrow, to the right following the drawn line, to the end arrow. Reposition if needed to follow the line. Add a basting box, sew it out then turn it off. Advance to **Color #2**.

Thread Color #2 **Bright Green (5324) # \_\_\_\_\_**  
Embroider the tree.

Thread Color #3 **Muslin (0870) # \_\_\_\_\_**  
Embroider the snowman.

Thread Color #4 **Wildfire (1800) # \_\_\_\_\_**  
Embroider the sack, present, bow and trim on hat.

Thread Color #5 **Spearmint (4240) # \_\_\_\_\_**  
Embroider the presents and rope.

Thread Color #6 **Dark Teal (4116) # \_\_\_\_\_**  
Embroider the hat and presents.

Thread Color #7 **Dawn of Violet (3130) # \_\_\_\_\_**  
Embroider the presents.

Thread Color #8 **Candlelight (0811) # \_\_\_\_\_**  
Embroider the presents and ribbon.

Thread Color #9 **Bright Mint (5610) # \_\_\_\_\_**  
Embroider the tree, holly, present and bows.

Thread Color #10 **Red Pepper (1304) # \_\_\_\_\_**  
Embroider the presents, ribbons and nose.

Thread Color #11 **Yellowgreen (6043) # \_\_\_\_\_**  
Embroider the tree.

Thread Color #12 **Nutmeg (0932) # \_\_\_\_\_**  
Embroider the arm.

Thread Color #13 **Black (0020) # \_\_\_\_\_**  
Embroider the outlining.

Remove the hoop from the module and the fabric from the hoop.

Gently remove the stabilizer & basting stitches from the back.

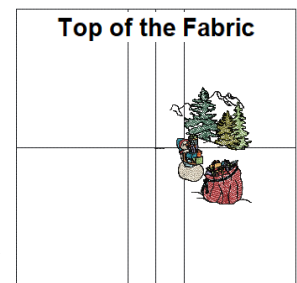
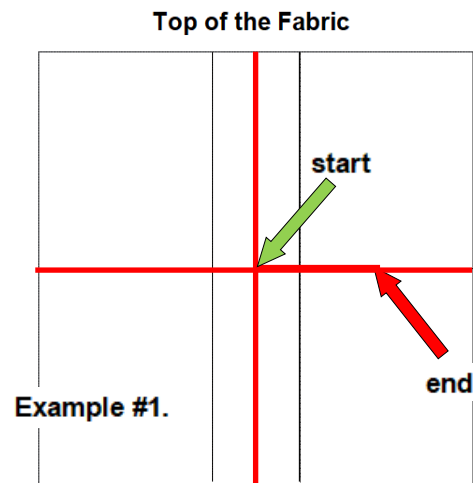



### 3 Bottom Row Folder / Christmas Folder / Gathering Presents / Hooping #2

Attach the hoop and the grid (no fabric) to the module.

#### Open #2 Snowman Tree

**Step #1** Advance to the **embroidery sewing screen** to go to the 1<sup>st</sup> stitch of the design.

**Step #2** Lower the needle, lay an arrow shaped post it note on the grid with the tip of the arrow touching the needle. (The arrow is positioned about 1 1/4" to the RIGHT & 1/2" ABOVE center on the grid).

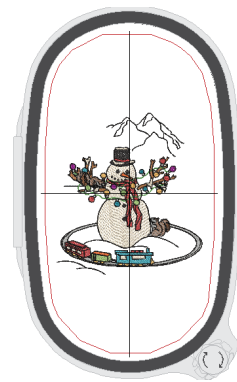

**Fabric Position:** To hoop this design position the **Top of the Fabric** at the top of the hoop. See **Example #2** below for 1<sup>st</sup> stitch position.

Top of the Fabric

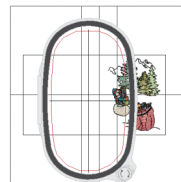

Hoop the fabric with the **arrow on the grid pointing to the green start arrow**.

See **Example #2**. The drawn lines on the fabric must be parallel and perpendicular to the lines on the grid.

Remove the grid from the hoop and attach the hoop to the module.

**Float tear away stabilizer** (sprayed with 505) **under the attached hoop**, MANDATORY!

No Thread, Color #1 **Placement Line**. The needle is positioned over the Center Crosshair **on the fabric**. See green start arrow in **Example #2**. Sew Color #1 without thread. It sews from the start arrow, to the left following the drawn line, to the end arrow. (Placement line shown in red) Reposition if needed. Add a basting box, sew it out then turn it off. Advance to **Color #2**.

Thread Color #2 **Nutmeg (0932) #** \_\_\_\_\_

Embroider the arms.

Thread Color #3 **Muslin (0870) #** \_\_\_\_\_

Embroider the snowman.

Thread Color #4 **Sterling (0142) #** \_\_\_\_\_

Embroider the train track & light sockets.

Thread Color #5 **Red Pepper (1304) #** \_\_\_\_\_

Embroider the nose and inside of middle train car.

Thread Color #6 **Wildfire (1800) #** \_\_\_\_\_

Embroider the scarf, lights, hat band, train car & stacks.

Thread Color #7 **Candlelight (0811) #** \_\_\_\_\_

Embroider the lights, wheels and front of engine.

Thread Color #8 **Caribbean Blue (4010) #** \_\_\_\_\_

Embroider the engine and light.

Thread Color #9 **Bright Mint (5610) #** \_\_\_\_\_

Embroider the lights and middle train car.

Thread Color #10 **Very Berry (2721) #** \_\_\_\_\_

Embroider the lights.

Thread Color #11 **Dark Teal (4116) #** \_\_\_\_\_

Embroider the lights.

Thread Color #12 **Emerald (5510) #** \_\_\_\_\_

Embroider the wire for the lights.

Thread Color #13 **Pony (1233) #** \_\_\_\_\_

Embroider the squirrel tails and nut.

Thread Color #14 **Sterling (0142) #** \_\_\_\_\_

Embroider the tail highlights.

Thread Color #15 **Pony (1233) #** \_\_\_\_\_

Embroider the shading on squirrel bodies

Thread Color #16 **Black (0020) #** \_\_\_\_\_

Embroider the outlining, hat, eyes and buttons.

Remove the hoop from the module and the fabric from the hoop.

Gently remove the stabilizer & basting stitches from the back.



Top of the Fabric

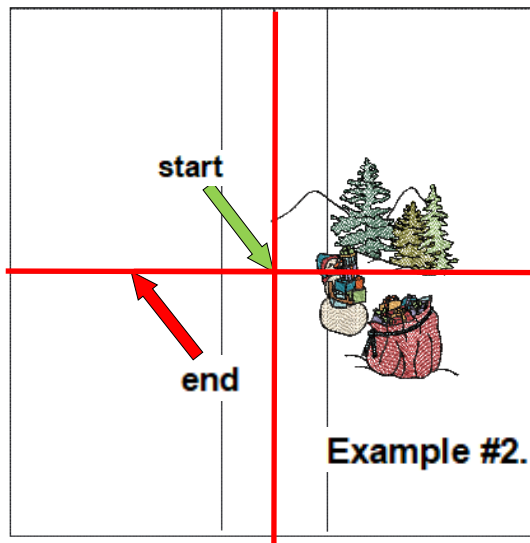

Top of the Fabric



### 3 Bottom Row Folder / Christmas Folder / Gathering Presents/ Hooping #3

Attach the hoop and the grid (no fabric) to the module.

#### Open #3 Trees & Presents

**Step #1** Advance to the **embroidery sewing screen** to go to the 1<sup>st</sup> stitch of the design.

**Step #2** Lower the needle, lay an arrow shaped post it note on the grid with the tip of the arrow touching the needle. (The arrow is positioned about 1/2" to the RIGHT & 2" ABOVE center on the grid).

**Fabric Position:** To hoop this design position the **Top of the Fabric** at the top of the hoop. See **Example #3 below** for 1st stitch position.

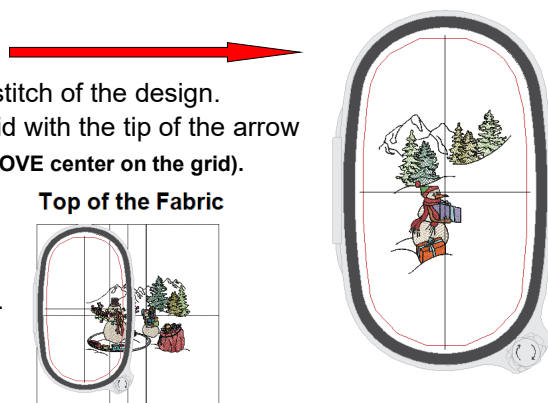

Hoop the fabric with the **arrow on the grid pointing to the green start arrow**.

See **Example #3**. The drawn lines on the fabric must be parallel and perpendicular to the lines on the grid.

Remove the grid from the hoop and attach the hoop to the module.

**Float tear away stabilizer** (sprayed with 505) **under the attached hoop**, MANDATORY!

No Thread, Color #1 **Placement Line**. The needle is positioned at the green start arrow. See green start arrow in **Example #3**. Sew Color #1 without thread.

**How to sew without thread:** use the **Broken Thread or Advance Stitch icon!!** See **Tips for Successful Embroidery**.

It sews from the start arrow, to the right following the stitched line, to the end arrow.

(Placement line shown in red) Reposition if needed.

Add a basting box, sew it out then turn it off. Advance to **Color #2**.

Thread Color #2 **Bright Green (5324) #** \_\_\_\_\_

Embroider the smaller tree.

Thread Color #3 **Muslin (0870) #** \_\_\_\_\_

Embroider the snowman.

Thread Color #4 **Bright Mint (5610) #** \_\_\_\_\_

Embroider the larger trees.

Thread Color #5 **Wildfire (1800) #** \_\_\_\_\_

Embroider the scarf and trim on hat.

Thread Color #6 **Emerald (5510) #** \_\_\_\_\_

Embroider the hat.

Thread Color #7 **Red Pepper (1304) #** \_\_\_\_\_

Embroider the present and nose.

Thread Color #8 **Dawn of Violet (3130) #** \_\_\_\_\_

Embroider the present.

Thread Color #9 **Spearmint (4240) #** \_\_\_\_\_

Embroider the ribbons.

Thread Color #10 **Nutmeg (0932) #** \_\_\_\_\_

Embroider the arm.

Thread Color #11 **Yellowgreen (6043) #** \_\_\_\_\_

Embroider the center trees.

Thread Color #12 **Black (0020) #** \_\_\_\_\_

Embroider the outlining and eyes.

Remove the hoop from the module and the fabric from the hoop.

Gently remove the stabilizer & basting stitches from the back.

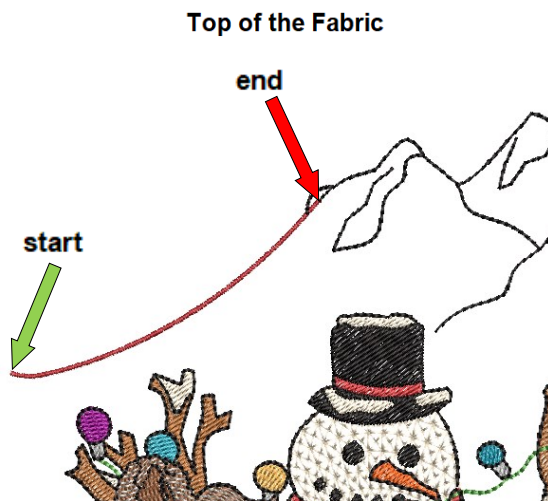

**Example #3.**

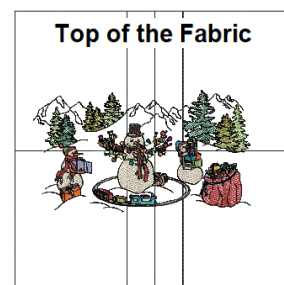



# WINTER VERSION



# WINTER VERSION

## Top Row / Winter Folder / Sledding

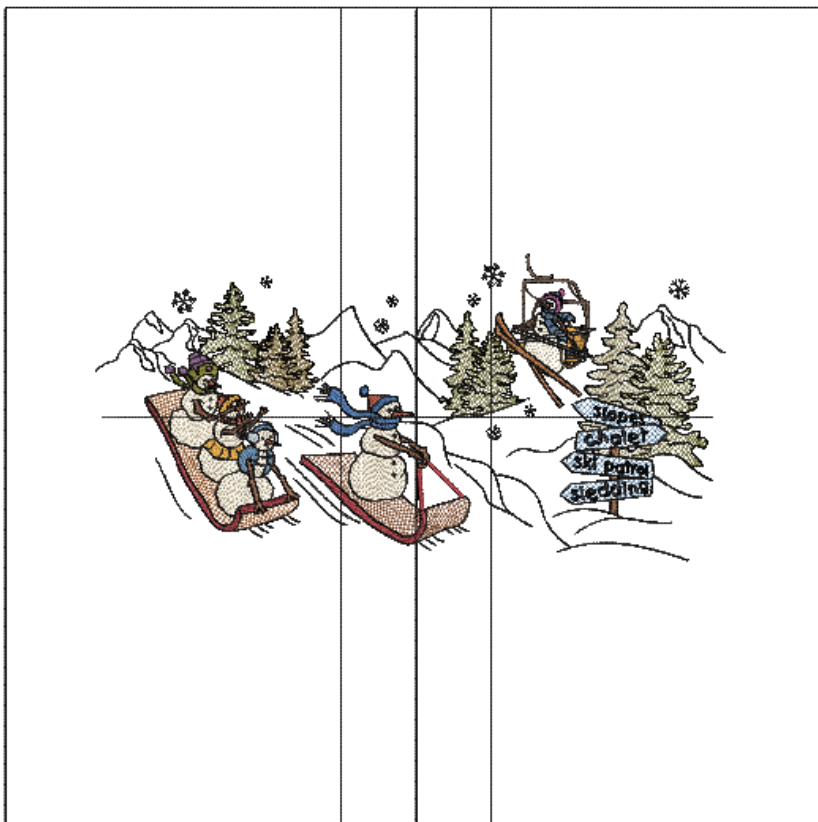

Cut Block 16 1/2" x 8 1/2"  
Finished Block 16" x 8"



# 1 Top Row Folder / Winter Folder / Sledding Folder / Hooping #1



Select the prepared Background Fabric. Select the folder with the format your machine reads.  
 Attach the hoop and the grid (no fabric) to the module.

Larger hoops may be able to combine Hoopings

## Open #1 Snowman

**Step #1** Advance to the **embroidery sewing screen** to go to the 1<sup>st</sup> stitch of the design.

**Step #2** Lower the needle, lay an arrow shaped post it note on the grid with the tip of the arrow touching the needle. (The arrow is positioned about 2" BELOW center on the grid).

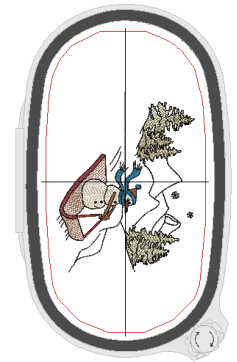

**Fabric Position:** To hoop this design the **Top of the Fabric** is **rotated** to the **RIGHT** of the hoop. See **Example #1** below for **1st stitch** position.

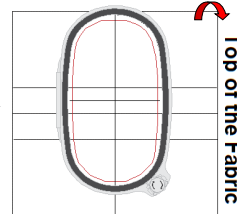

Hoop the fabric with the **arrow on the grid pointing to the green start arrow**.

See **Example #1**. The drawn lines on the fabric must be parallel and perpendicular to the lines on the grid.

Remove the grid from the hoop and attach the hoop to the module.

**Float tear away stabilizer** (sprayed with 505) **under the attached hoop**, MANDATORY!

No Thread, Color #1 **Placement Line**. The needle is positioned over the **Center Crosshair on the fabric**.

See green start arrow in **Example #1**. Sew Color #1 without thread.

**How to sew without thread:** use the **Broken Thread** or **Advance Stitch** icon!! See **Tips for Successful Embroidery**.

It sews from the start arrow, upward following the drawn line, to the end arrow. (Placement line shown in red)  
 Reposition if needed. Add a basting box, sew it out then turn it off.

Advance to **Color #2**.

Thread Color #2 **Moss (0345) #** \_\_\_\_\_  
 Embroider the trees (it will look like 1 big tree but it's 2).

Thread Color #3 **Muslin (0870) #** \_\_\_\_\_  
 Embroider the snowman.

Thread Color #4 **Pony (1233) #** \_\_\_\_\_  
 Embroider the sled.

Thread Color #5 **Moss Green (5934) #** \_\_\_\_\_  
 Embroider the outer trees.

Thread Color #6 **Dark Rust (1335) #** \_\_\_\_\_  
 Embroider the nose and knit hat.

Thread Color #7 **Colonial Blue (3902) #** \_\_\_\_\_  
 Embroider the scarf and pompom.

Thread Color #8 **Foliage Rose (1911) #** \_\_\_\_\_  
 Embroider the edge of the sled and rope handle.

Thread Color #9 **Nutmeg (0932) #** \_\_\_\_\_  
 Embroider the arms.

Thread Color #10 **Black (0020) #** \_\_\_\_\_  
 Embroider the outlining, eyes & mountains.

Remove the hoop from the module  
 and the fabric from the hoop.



Gently remove the stabilizer & basting stitches from the back.

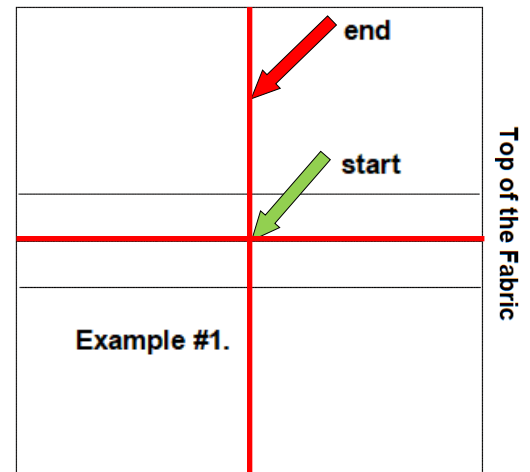

**Top of the Fabric**

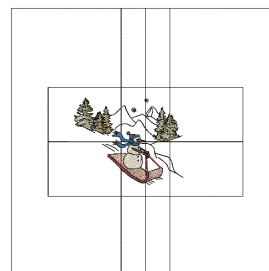

# 1 Top Row Folder / Winter Folder / Sledding Folder / Hooping #2

Attach the hoop and the grid (no fabric) to the module.

## Open #2 Sledding

**Step #1** Advance to the **embroidery sewing screen** to go to the 1<sup>st</sup> stitch of the design.

**Step #2** Lower the needle, lay an arrow shaped post it note on the grid with the tip of the arrow touching the needle. (The arrow is positioned about ½” to the LEFT & 2 ½” BELOW center on the grid).

Use stabilizer to extend the fabric surface to eliminate any “gap of fabric” inside the hoop

**Fabric Position:** To hoop this design the **Top of the Fabric** is **rotated** to the **RIGHT** of the hoop.

See **Example #2** below for **1st stitch** position.

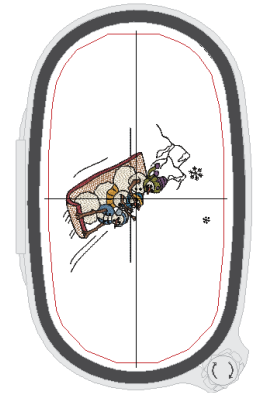
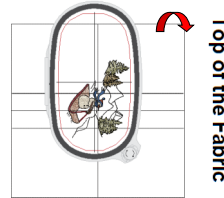

Hoop the fabric with the **arrow on the grid pointing to the green start arrow**.

See **Example #2**. The drawn lines on the fabric must be parallel and perpendicular to the lines on the grid.

Remove the grid from the hoop and attach the hoop to the module.

**Float tear away stabilizer** (sprayed with 505) **under the attached hoop**, MANDATORY!

No Thread, Color #1 **Placement Line**. The needle is positioned **2” above the Center Crosshair on the fabric**.

See green start arrow in **Example #2**. Sew Color #1 without thread.

**How to sew without thread:** use the **Broken Thread** or **Advance Stitch** icon!! See **Tips for Successful Embroidery**.

It sews from the start arrow, upward following the drawn line, to the end arrow. (Placement line shown in red)  
Reposition if needed. Add a basting box, sew it out then turn it off. **Advance to Color #2**.

Thread Color #2 **Muslin (0870) #** \_\_\_\_\_  
Embroider the snowmen.

Thread Color #3 **Orchid (2810) #** \_\_\_\_\_  
Embroider the hat (will cover some of the tree).

Thread Color #4 **Winter Frost (3750) #** \_\_\_\_\_  
Embroider the ear muffs.

Thread Color #5 **Foliage Rose (1911) #** \_\_\_\_\_  
Embroider the edge of the sled.

Thread Color #6 **Laguna (3810) #** \_\_\_\_\_  
Embroider the vest and head band.

Thread Color #7 **Dark Rust (1335) #** \_\_\_\_\_  
Embroider the noses.

Thread Color #8 **Colonial Blue (3902) #** \_\_\_\_\_  
Embroider the knit hat and scarf.

Thread Color #9 **Gold (0704) #** \_\_\_\_\_  
Embroider the knit hat and apron.

Thread Color #10 **Nutmeg (0932) #** \_\_\_\_\_  
Embroider the arms.

Thread Color #11 **Yellowgreen (6043) #** \_\_\_\_\_  
Embroider the hat and scarf.

Thread Color #12 **Pony (1233) #** \_\_\_\_\_  
Embroider the base of the sled.

Thread Color #13 **Black (0020) #** \_\_\_\_\_  
Embroider the outlining and eyes.

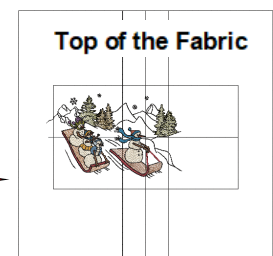
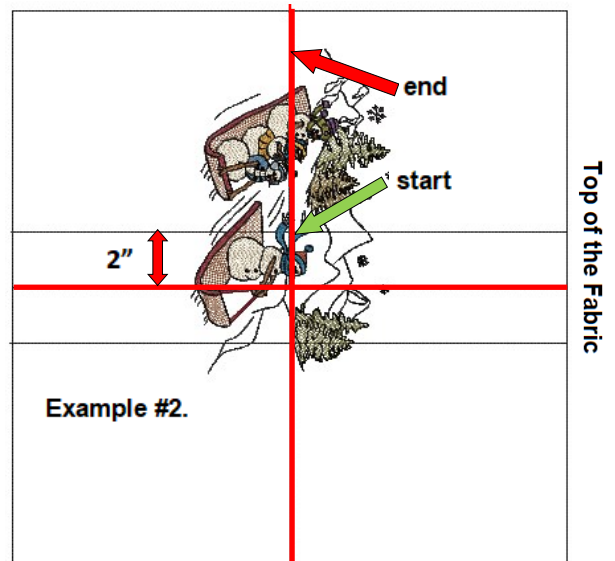

Remove the hoop from the module and the fabric from the hoop.

Gently remove the stabilizer & basting stitches from the back.

# 1 Top Row Folder / Winter Folder / Sledding Folder / Hooping #3

Attach the hoop and the grid (no fabric) to the module.

## Open #3 Lift

**Step #1** Advance to the **embroidery sewing screen** to go to the 1<sup>st</sup> stitch of the design.

**Step #2** Lower the needle, lay an arrow shaped post it note on the grid with the tip of the arrow touching the needle. (The arrow is positioned about 3" to the LEFT & 1/2" BELOW center on the grid).

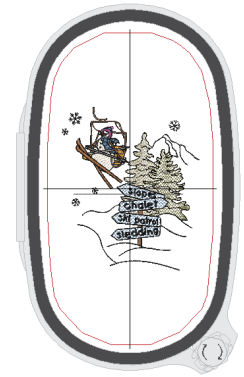

**Fabric Position:** To hoop this design the **Top of the Fabric** is positioned at the hoop.

See **Example #3** below for 1st stitch position.

Top of the Fabric

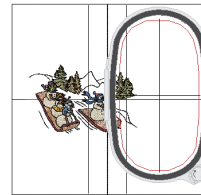

Hoop the fabric with the **arrow on the grid pointing to the green start arrow**.

See **Example #3**. The drawn lines on the fabric must be parallel and perpendicular to the lines on the grid.

Remove the grid from the hoop and attach the hoop to the module.

**Float tear away stabilizer** (sprayed with 505) **under the attached hoop**, MANDATORY!

No Thread, Color #1 **Placement Line**. The needle is positioned **2" to the right of the Center Crosshair** on the fabric.

See green start arrow in **Example #3**. Sew Color #1 without thread. It sews from the start arrow, to the right, following the drawn line, to the end arrow. (Placement line shown in red) Reposition if needed.

Add a basting box, sew it out then turn it off. Advance to **Color #2**.

Thread Color #2 **Army Drab (0453) #** \_\_\_\_\_

Embroider the left tree.

Thread Color #3 **Muslin (0870) #** \_\_\_\_\_

Embroider the snowman.

Thread Color #4 **Moss Green (5934) #** \_\_\_\_\_

Embroider the right tree.

Thread Color #5 **Gold (0704) #** \_\_\_\_\_

Embroider the chair.

Thread Color #6 **Peony (2723) #** \_\_\_\_\_

Embroider the knit hat.

Thread Color #7 **Laguna (3810) #** \_\_\_\_\_

Embroider the signs and scarf.

Thread Color #8 **Pony (1233) #** \_\_\_\_\_

Embroider the sign post and skis.

Thread Color #9 **Dark Rust (1335) #** \_\_\_\_\_

Embroider the nose.

Thread Color #10 **Chocolate (1876) #** \_\_\_\_\_

Embroider the chair lift frame.

Thread Color #11 **Sterling (0142) #** \_\_\_\_\_

Embroider the ski poles.

Thread Color #12 **Nutmeg (0932) #** \_\_\_\_\_

Embroider the arms.

Thread Color #13 **Black (0020) #** \_\_\_\_\_

Embroider the outlining, snowflakes & mountains.

Remove the hoop from the module and the fabric from the hoop.

Gently remove the stabilizer & basting stitches from the back.

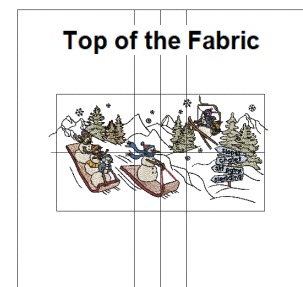
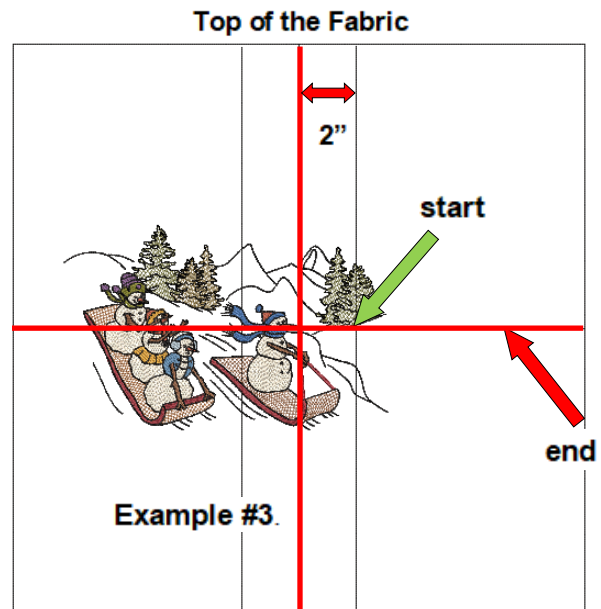

# WINTER VERSION

## Top Row / Winter Folder / Smores



Cut Block 13" x 8 1/2"  
Finished Block 12 1/2" x 8"



# 1 Top Row / Winter Folder / Smores Folder / Hooping #1

Select the prepared 20" x 20" Background Fabric. Select the folder with the format your machine reads. Attach the hoop and the grid (no fabric) to the module.

Larger Hoops may be able to combine Hoopings

## Open #1 Smores

**Step #1** Advance to the **embroidery sewing screen** to go to the 1<sup>st</sup> stitch of the design.

**Step #2** Lower the needle, lay an arrow shaped post it note on the grid with the tip of the arrow touching the needle. (The arrow is positioned about 3" to the LEFT just below center on the grid).

**Fabric Position:** To hoop this design the **Top of the Fabric** is positioned at the top of the hoop.

See **Example #1** below for 1st stitch position.



Top of the Fabric

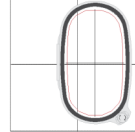

Hoop the fabric with the **arrow on the grid pointing to the Center Crosshair on the FABRIC.**

See **Example #1.** The drawn lines on the fabric must be parallel and perpendicular to the lines on the grid.

Remove the grid from the hoop and attach the hoop to the module.

**Float tear away stabilizer** (sprayed with 505) **under the attached hoop, MANDATORY!**

No Thread, Color #1 **Placement Line.** The needle is positioned over the Center Crosshair **on the fabric.** See green start arrow in **Example #1.** Sew Color #1 without thread.

**How to sew without thread: use the Broken Thread or Advance Stitch icon!! See Tips for Successful Embroidery.**

It sews from the start arrow, to the right following the drawn line, to the end arrow.

Reposition if needed to follow the line. Add a basting box, sew it out then turn it off. Advance to **Color #2.**

Thread Color #2 **Yellowgreen (6043) # \_\_\_\_\_**  
Embroider the tree & mallow's sack.

Thread Color #3 **Muslin (0870) # \_\_\_\_\_**  
Embroider the snowman & marshmallows.

Thread Color #4 **Moss (0345) # \_\_\_\_\_**  
Embroider the tree.

Thread Color # 5 **Gold (0704) # \_\_\_\_\_**  
Embroider the fire and packaging labels.

Thread Color #6 **Pony (1233) # \_\_\_\_\_**  
Embroider the fire logs, end of log and stick.

Thread Color #7 **Peony (2723) # \_\_\_\_\_**  
Embroider the scarf & hat.

Thread Color #8 **Nutmeg (0932) # \_\_\_\_\_**  
Embroider the arms and end of package (not touching the gold).

Thread Color #9 **Rough Sea (4332) # \_\_\_\_\_**  
Embroider the graham box.

Thread Color #10 **Foliage Rose (1911) # \_\_\_\_\_**  
Embroider the trims areas on the packages.

Thread Color #11 **Dark Rust (1335) # \_\_\_\_\_**  
Embroider the fire and nose.

Thread Color #12 **Black (0020) # \_\_\_\_\_**  
Embroider the outlining.

Remove the hoop from the module and the fabric from the hoop.  
Gently remove the stabilizer & basting stitches from the back.

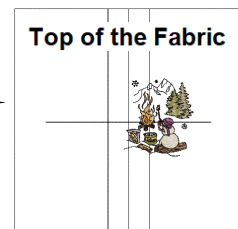
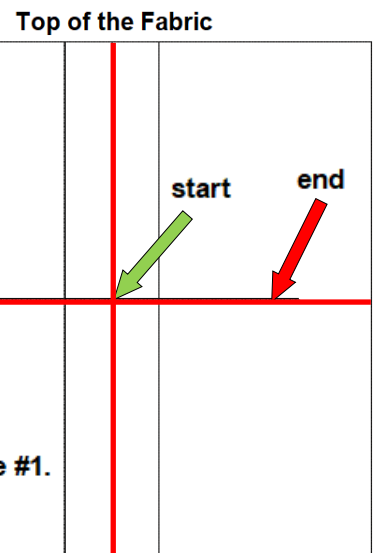

## 1 Top Row Folder / Winter Folder/ Smores Folder / Hooping #2

Attach the hoop and the grid (no fabric) to the module.

### Open #2 Couple

**Step #1** Advance to the **embroidery sewing screen** to go to the 1<sup>st</sup> stitch of the design.

**Step #2** Lower the needle, lay an arrow shaped post it note on the grid with the tip of the arrow touching the needle. (The arrow is positioned about 2 ½" to the RIGHT just ABOVE center on the grid).

**Fabric Position:** To hoop this design the **Top of the Fabric** is positioned at the top of the hoop.

See **Example #2** below for 1st stitch position.

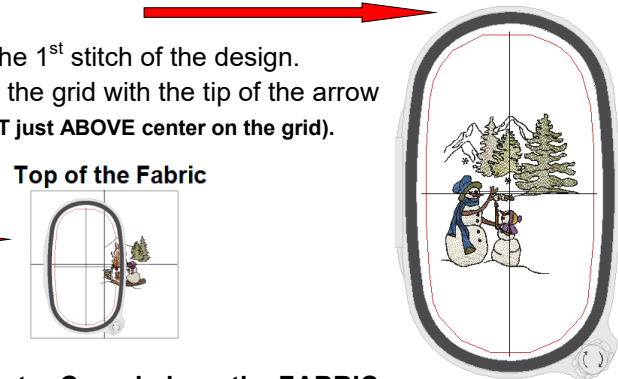

Hoop the fabric with the **arrow on the grid pointing to the Center Crosshair on the FABRIC.**

See **Example #2**. The drawn lines on the fabric must be parallel and perpendicular to the lines on the grid.

Remove the grid from the hoop and attach the hoop to the module.

**Float 2 pieces of tear away stabilizer** (sprayed with 505) **under the attached hoop, MANDATORY!**

No Thread, Color #1 **Placement Line**. The needle is positioned over the Center Crosshair **on the fabric**. See green start arrow in **Example #2**. Sew Color #1 without thread.

**How to sew without thread: use the Broken Thread or Advance Stitch icon!! See Tips for Successful Embroidery.**

It sews from the start arrow, to the left following the drawn line, to the end arrow.

Reposition if needed to follow the line.

Add a basting box, sew it out then turn it off. Advance to **Color #2**.

Thread Color #2 **Muslin (0870) # \_\_\_\_\_**

Embroider the snowmen.

Thread Color #3 **Army Drab (0453) # \_\_\_\_\_**

Embroider the left tree.

Thread Color #4 **Moss Green (5934) # \_\_\_\_\_**

Embroider the right tree and hat & scarf trim.

Thread Color #5 **Dark Rust (1335) # \_\_\_\_\_**

Embroider the noses.

Thread Color #6 **Yellowgreen (6043) # \_\_\_\_\_**

Embroider the center tree.

Thread Color #7 **Colonial Blue (3902) # \_\_\_\_\_**

Embroider the hat and scarf.

Thread Color #8 **Orchid (2810) # \_\_\_\_\_**

Embroider the hat and cape.

Thread Color #9 **Gold (0704) # \_\_\_\_\_**

Embroider the candle and hat.

Thread Color #10 **Nutmeg (0932) # \_\_\_\_\_**

Embroider the arms.

Thread Color #11 **Black (0020) # \_\_\_\_\_**

Embroider the outlining, mountains & snowflakes.

Remove the hoop from the module and the fabric from the hoop.

Gently remove the stabilizer & basting stitches from the back.

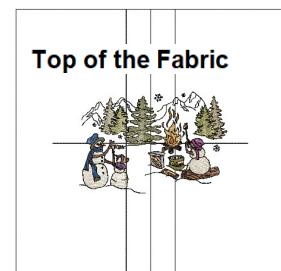
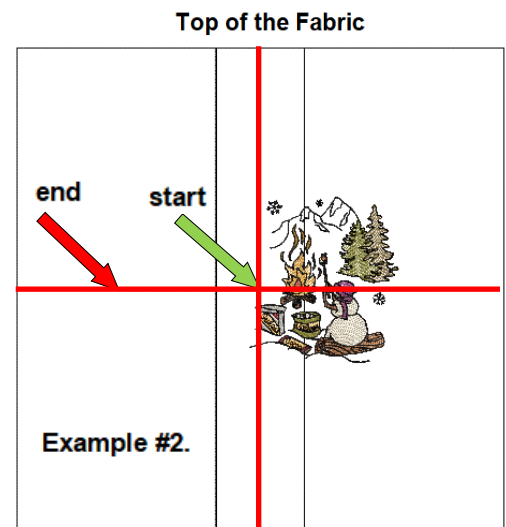

# WINTER VERSION

## Middle Row / Winter Folder

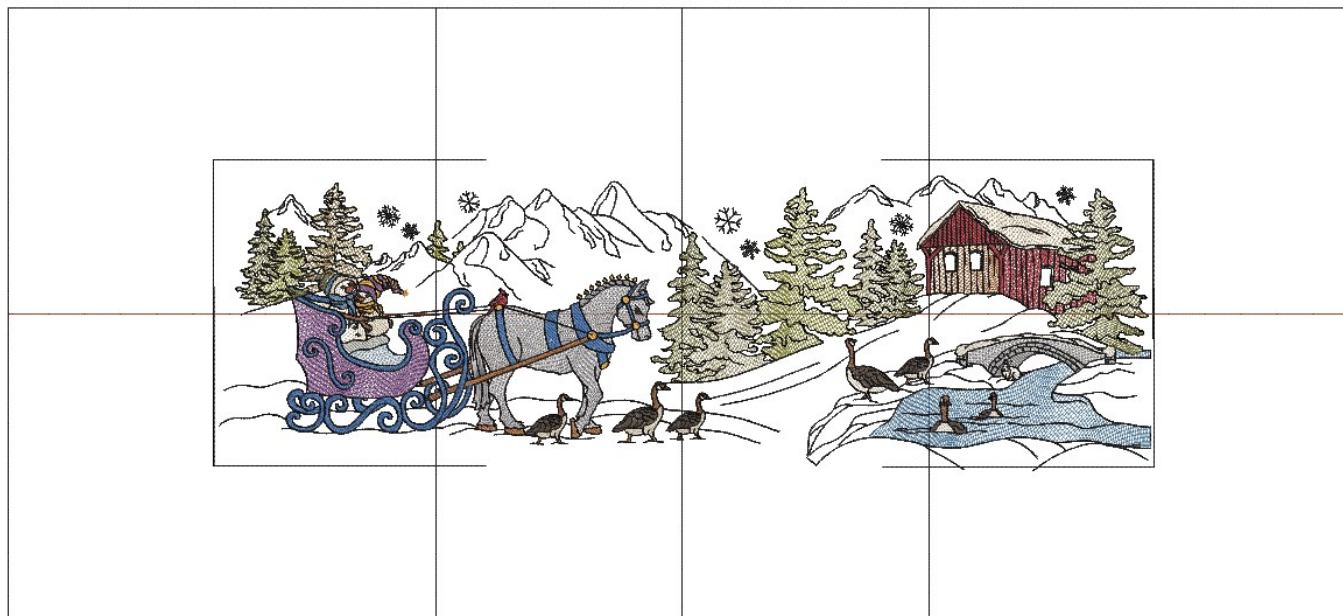

Cut Block 30 1/2" x 9 1/2"  
Finished Block 30" x 9"

## 2 Middle Row / Winter Folder / Hooping #1

Select the prepared 42" x 20" Background Fabric.  
 Select the folder with the format your machine reads.

Attach the hoop and the grid (no fabric) to the module.

### Open #1 Center Trees

**Step #1** Advance to the **embroidery sewing screen** to go to the 1<sup>st</sup> stitch of the design.  
**Step #2** Lower the needle, lay an arrow shaped post it note on the grid with the tip of the arrow touching the needle. (The arrow is positioned just to left and about 3 1/4" ABOVE center on the grid).

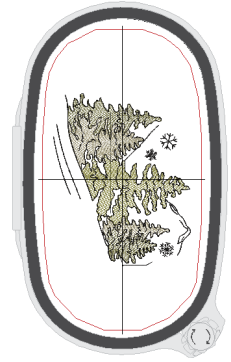

**Fabric Position:** To hoop this design the **Top of the Fabric** is **rotated** to the **RIGHT** of the hoop.  
 See **Example #1** below for **1st stitch** position.

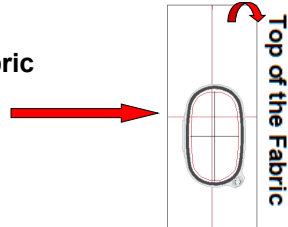

Hoop the fabric with the **arrow on the grid pointing to the center crosshair on the FABRIC**. See **Example #1**. The drawn lines on the fabric must be parallel and perpendicular to the lines on the grid. Remove the grid from the hoop and attach the hoop to the module.  
**Float tear away stabilizer** (sprayed with 505) **under the attached hoop**. Mandatory!

Try one layer, if the outlining touches the fills correctly just use one layer.  
 If there is a gap between the object and the outlining use two layers of stabilizer.

### No Thread, Color #1 Placement Line.

The needle is positioned over the center crosshair **on the fabric**. See green start arrow in **Example #1**. Sew Color #1 without thread.

**How to sew without thread: use the Broken Thread or Advance Stitch icon!!**  
 See **Tips for Successful Embroidery**.

It sews downward 5" following the drawn line. Reposition if needed.  
 Add a basting box, sew it out then turn it off. Advance to **Color #2**.

- Thread Color #2 **Yellowgreen (6043) #** \_\_\_\_\_  
 Embroider the center tree.
- Thread Color #3 **Moss Green (5934) #** \_\_\_\_\_  
 Embroider the outside trees.
- Thread Color #4 **Army Drab (0453) #** \_\_\_\_\_  
 Embroider the inside trees.
- Thread Color #5 **Black (0020) #** \_\_\_\_\_  
 Embroider the outlining and snowflakes.

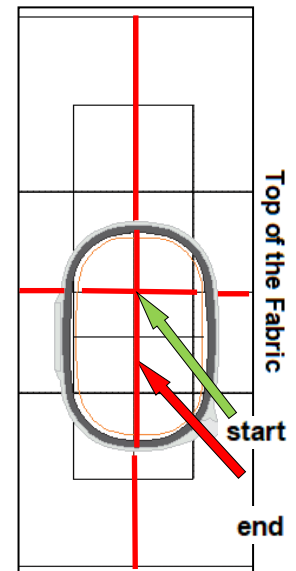

**Example #1.**

Remove the hoop from the module and the fabric from the hoop.  
 Gently remove the stabilizer & basting stitches from the back.

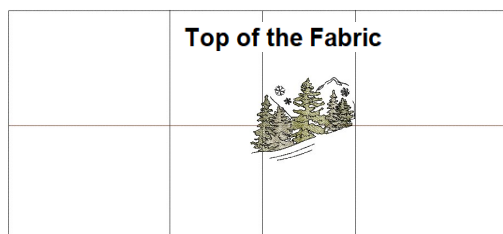



## 2 Middle Row / Winter Folder / Hooping #2

Attach the hoop and the grid (no fabric) to the module.

Larger Hoops may be able to combine Hoopings

### Open #2 Barn

**Step #1** Advance to the **embroidery sewing screen** to go to the 1<sup>st</sup> stitch of the design.

**Step #2** Lower the needle, lay an arrow shaped post it note on the grid with the tip of the arrow touching the needle. (The arrow is positioned about 1 1/2" to left and 3 1/4" ABOVE center on the grid).

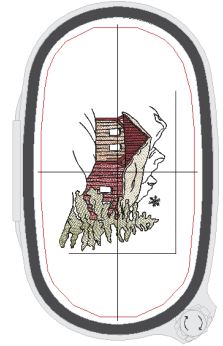

**Fabric Position:** To hoop this design the **Top of the Fabric** is **rotated** to the **RIGHT** of the hoop.

See **Example #2** below for **1st stitch** position.

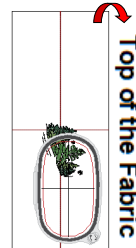

Hoop the fabric with the **arrow on the grid pointing to the green start arrow**.

See **Example #2**. The drawn lines on the fabric must be parallel and perpendicular to the lines on the grid. Remove the grid from the hoop and attach the hoop to the module.

**Float tear away stabilizer** (sprayed with 505) **under the attached hoop**.

### No Thread, Color #1 Placement Line.

The needle is positioned at the green start arrow.

See green start arrow in **Example #2**. Sew Color #1 without thread.

**How to sew without thread: use the Broken Thread or Advance Stitch icon!!**

It sews from the start to the end arrow following the stitched in black line. (Placement line shown in red). Reposition if needed.

Add a basting box, sew it out then turn it off. Advance to **Color #2**.

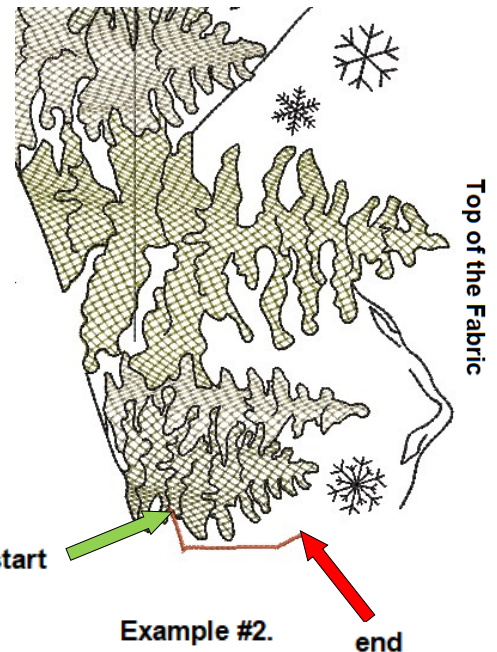

Thread Color #2 **Nutmeg (0932)** # \_\_\_\_\_

Embroider the inside of the barn.

Thread Color #3 **Foliage Rose (1911)** # \_\_\_\_\_

Embroider the outside of the barn.

Thread Color #4 **Muslin (0870)** # \_\_\_\_\_

Embroider the snow on the roof.

Thread Color #5 **Moss Green (5934)** # \_\_\_\_\_

Embroider the tree.

Thread Color #6 **Black (0020)** # \_\_\_\_\_

Embroider the outlining, snowflakes & "corner placement lines".

**(Do not remove the corner placement lines yet. Be careful removing the stabilizer.)**

Remove the hoop from the module and the fabric from the hoop.

Gently remove the stabilizer & basting stitches from the back.

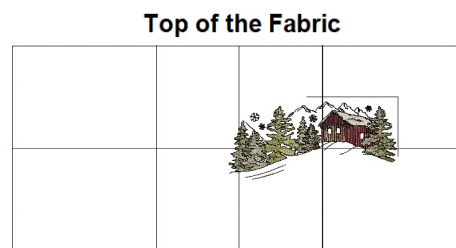

## 2 Middle Row/ Winter Folder / Hooping #3

Attach the hoop and the grid (no fabric) to the module.

### Open #3 River

**Step #1** Advance to the **embroidery sewing screen** to go to the 1<sup>st</sup> stitch of the design.

**Step #2** Lower the needle, lay an arrow shaped post it note on the grid with the tip of the arrow touching the needle. (The arrow is positioned about 1 1/2" to RIGHT and 2 1/2" BELOW center on the grid).

**Fabric Position:** To hoop this design the **Top of the Fabric** is rotated to the **RIGHT** of the hoop. See **Example #3** below for 1st stitch position.

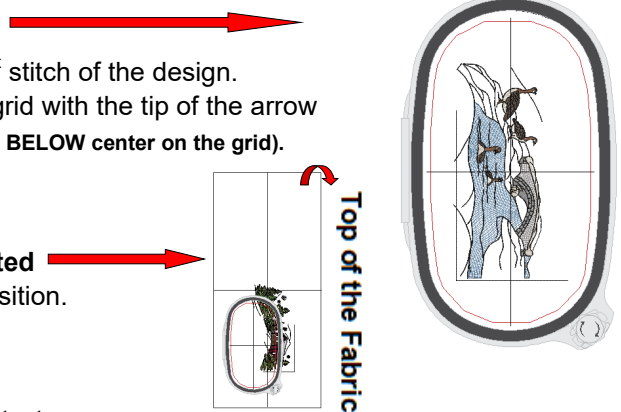

Hoop the fabric with the **arrow on the grid pointing to the green start arrow**.

See **Example #3**. The drawn lines on the fabric must be parallel and perpendicular to the lines on the grid.

Remove the grid. **Float tear away stabilizer** (sprayed with 505) **under the attached hoop**.

### No Thread, Color #1 Placement Line.

The needle is positioned at the green start arrow see **Example #3**. Sew Color #1 without thread.

**How to sew without thread:** use the **Broken Thread** or **Advance Stitch** icon!! See **Tips for Successful Embroidery**.

It sews downward following the stitched in black line & continues following the outer edge of the green tree. (Placement Line shown in red). Reposition if needed.

Add a basting box, sew it out then turn it off.

Advance to **Color #2**.

Thread Color #2 **Silvery Grey (1972) # \_\_\_\_\_**  
Embroider the bridge.

Thread Color #3 **Nutmeg (0932) # \_\_\_\_\_**  
Embroider the feet.

Thread Color #4 **Laguna (3810) # \_\_\_\_\_**  
Embroider the river.

Thread Color #5 **Pony (1233) # \_\_\_\_\_**  
Embroider the geese necks.

Thread Color #6 **Sterling (0142) # \_\_\_\_\_**  
Embroider the bricks on the bridge.

Thread Color #7 **Chocolate (1876) # \_\_\_\_\_**  
Embroider the geese feathers.

Thread Color #8 **Muslin (0870) # \_\_\_\_\_**  
Embroider the snow, geese, bunny.

Thread Color #9 **Black (0020) # \_\_\_\_\_**  
Embroider the outlining & **"corner placement lines"**

(Do not remove these lines yet be careful removing the stabilizer.)

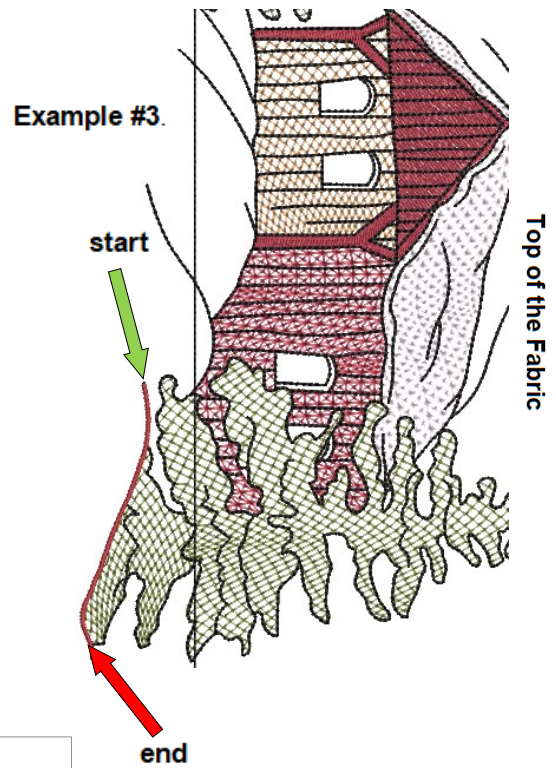

Remove the hoop from the module and the fabric from the hoop.

Gently remove the stabilizer & basting stitches from the back.

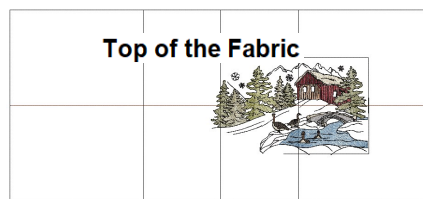

## 2 Middle Row / Winter Folder / Hooping #4

Attach the hoop and the grid (no fabric) to the module.

### Open #4 Mountains

**Step #1** Advance to the **embroidery sewing screen** to go to the 1<sup>st</sup> stitch of the design.

**Step #2** Lower the needle, lay an arrow shaped post it note on the grid with the tip of the arrow touching the needle. (The arrow is positioned about 1 1/2" to LEFT and 5" BELOW center on the grid).

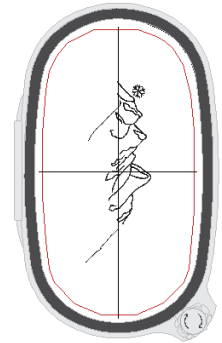

**Fabric Position:** To hoop this design the **Top of the Fabric** is rotated to the **RIGHT** of the hoop.

See **Example #4** below for 1st stitch position.

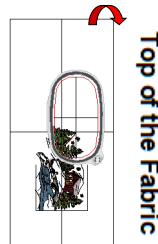

Hoop the fabric with the **arrow on the grid pointing to the green start arrow**.

See **Example #4**. The drawn lines on the fabric must be parallel and perpendicular to the lines on the grid.

Remove the grid from the hoop and attach the hoop to the module.

**Float tear away stabilizer** (sprayed with 505) **under the attached hoop**.

### No Thread, Color #1 Placement Line.

The needle is positioned at the green start arrow see

**Example #4**. Sew Color #1 without thread.

How to sew without thread: use the **Broken Thread** or **Advance Stitch** icon!!

See **Tips for Successful Embroidery**.

It sews from the start to the end arrow following the black stitched in line. (Placement Line shown in red).  
Reposition if needed.

Add a basting box, sew it out then turn it off.

Advance to **Color #2**.

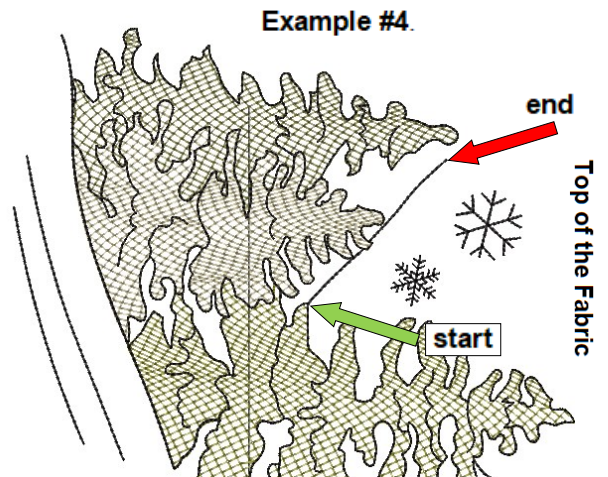

Thread Color #2 **Black (0020) # \_\_\_\_\_**

Embroider the outlining and snowflakes.

Remove the hoop from the module  
and the fabric from the hoop.



Gently remove the stabilizer & basting stitches from the back.

**Top of the Fabric**

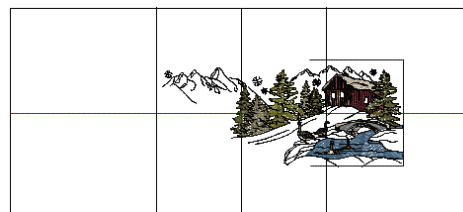

## 2 Middle Row / Winter Folder / Hooping #5

Attach the hoop and the grid (no fabric) to the module.

### Open #5 Corner Trees

**Step #1** Advance to the **embroidery sewing screen** to go to the 1<sup>st</sup> stitch of the design.

**Step #2** Lower the needle, lay an arrow shaped post it note on the grid with the tip of the arrow touching the needle. (The arrow is positioned about 1 1/2" to LEFT and 5 1/4" BELOW center on the grid).

**Fabric Position:** To hoop this design the **Top of the Fabric is rotated to the RIGHT** of the hoop. See **Example #5** below for 1st stitch position.

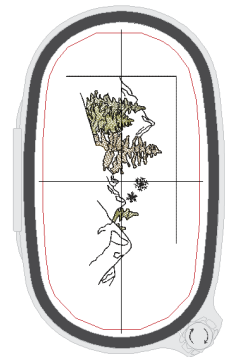
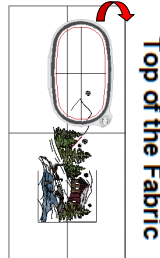

Hoop the fabric with the **arrow on the grid pointing to the green start arrow**. See **Example #5**.

The drawn lines on the fabric must be parallel and perpendicular to the lines on the grid.

Remove the grid from the hoop and attach the hoop to the module.

**Float tear away stabilizer** (sprayed with 505) **under the attached hoop**.

To the left of the Snowflake

### No Thread, Color #1 Placement Line.

The needle is positioned at the green start arrow see

**Example #5**. Sew Color #1 without thread.

**How to sew without thread:** use the **Broken Thread** or **Advance Stitch** icon!!

See **Tips for Successful Embroidery**.

It sews upward following the stitched in black line (Placement Line shown in red).

Reposition if needed. Add a basting box,

sew it out then turn it off. Advance to **Color #2**.

Thread Color #2 **Yellowgreen (6043)** # \_\_\_\_\_  
Embroider two trees.

Thread Color #3 **Moss (0345)** # \_\_\_\_\_  
Embroider the center tree.

Thread Color #4 **Moss Green (5934)** # \_\_\_\_\_  
Embroider the remaining tree.

Thread Color #5 **Black (0020)** # \_\_\_\_\_  
Embroider the outlining, snowflakes & **"corner placement lines"**

**(Do not remove these lines yet. Be careful removing the stabilizer.)**

Remove the hoop from the module and the fabric from the hoop.

Gently remove the stabilizer & basting stitches from the back.

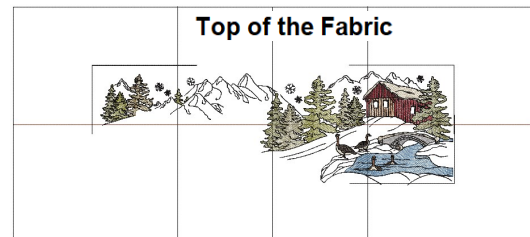
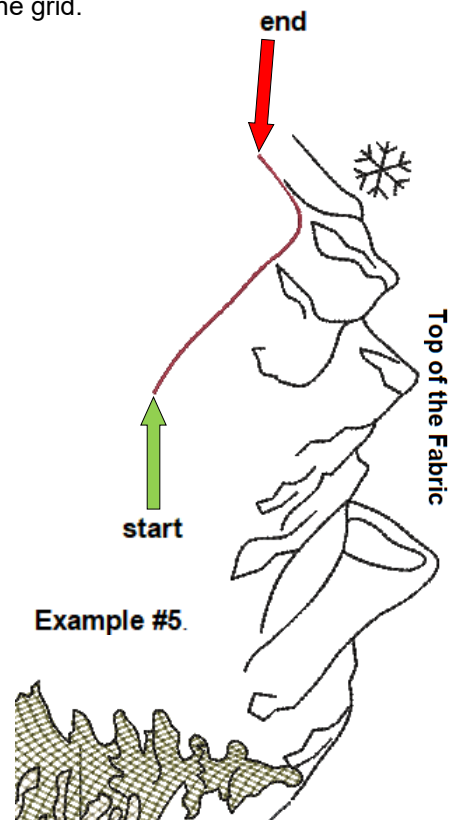



## 2 Middle Row / Winter Folder / Hooping #6

Attach the hoop and the grid (no fabric) to the module.

### Open #6 Sleigh

**Step #1** Advance to the **embroidery sewing screen** to go to the 1<sup>st</sup> stitch of the design.

**Step #2** Lower the needle, lay an arrow shaped post it note on the grid with the tip of the arrow touching the needle. (The arrow is positioned about 3" to RIGHT and 1" BELOW center on the grid).

**Fabric Position:** To hoop this design the **Top of the Fabric** is **rotated** to the **RIGHT** of the hoop.

See **Example #6** below for 1<sup>st</sup> stitch position.

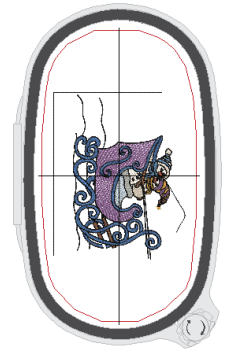
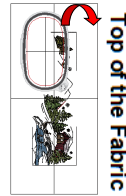

Hoop the fabric with the **arrow on the grid pointing to the green start arrow**. See **Example #6**. The drawn lines on the fabric must be parallel and perpendicular to the lines on the grid. Remove the grid from the hoop and attach the hoop to the module. **Float tear away stabilizer** (sprayed with 505) **under the attached hoop**.

### No Thread, Color #1 Placement Line.

The needle is positioned at the green start arrow see **Example #6**. Sew Color #1 without thread.

**How to sew without thread:** use the **Broken Thread** or **Advance Stitch** icon!! See **Tips for Successful Embroidery**.

It sews downward following the stitched in black line of the Mountain shape. (Placement Line shown in red).

Reposition if needed. Add a basting box, sew it out then turn it off.

Advance to **Color #2**.

Thread Color #2 **Orchid (2810) # \_\_\_\_\_**  
Embroider the sleigh (sews over tree) and hat stripes.

Thread Color #3 **Muslin (0870) # \_\_\_\_\_**  
Embroider the snowman (sews over the tree), stripes on hat and muffler.

Thread Color #4 **Colonial Blue (3902) # \_\_\_\_\_**  
Embroider the sleigh runners.

Thread Color #5 **Laguna (3810) # \_\_\_\_\_**  
Embroider the scarf and hat stripes.

Thread Color #6 **Rough Sea (4332) # \_\_\_\_\_**  
Embroider the top of the blanket.

Thread Color #7 **Nutmeg (0932) # \_\_\_\_\_**  
Embroider the arms and sleigh bars.

Thread Color #8 **Winter Frost (3750) # \_\_\_\_\_**  
Embroider the blanket.

Thread Color #9 **Dark Rust (1335) # \_\_\_\_\_**  
Embroider the noses.

Thread Color #10 **Gold (0704) # \_\_\_\_\_**  
Embroider the scarf and hat stripes.

Thread Color #11 **Black (0020) # \_\_\_\_\_**  
Embroider the outlining & "corner placement lines"

(Do not remove the corner placement lines yet.  
Be careful removing the stabilizer.)

Remove the hoop from the module and the fabric from the hoop.

Gently remove the stabilizer & basting stitches from the back.

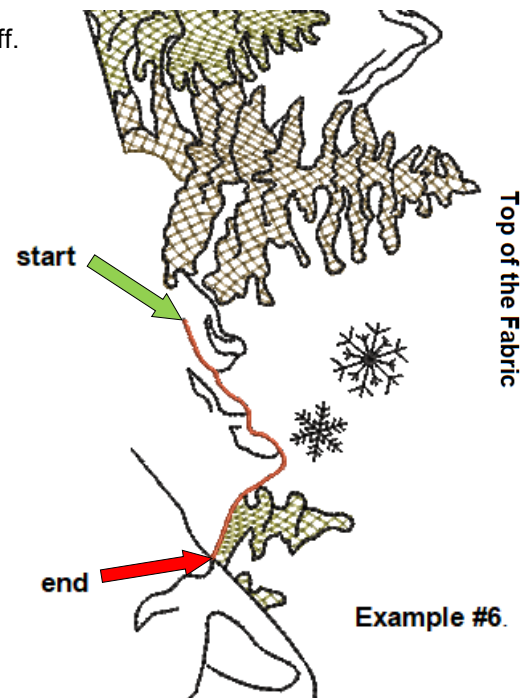

Example #6.

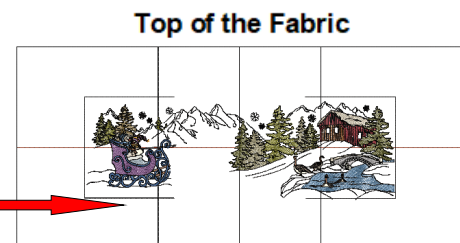

## 2 Middle Row / Winter Folder / Hooping #7

Attach the hoop and the grid (no fabric) to the module.

### Open #7 Horse

**Step #1** Advance to the **embroidery sewing screen** to go to the 1<sup>st</sup> stitch of the design.

**Step #2** Lower the needle, lay an arrow shaped post it note on the grid with the tip of the arrow touching the needle. (The arrow is positioned about 2" to RIGHT and 5" ABOVE center on the grid).

**Fabric Position:** To hoop this design the **Top of the Fabric** is rotated to the **RIGHT** of the hoop. See **Example #7** below for 1st stitch position.

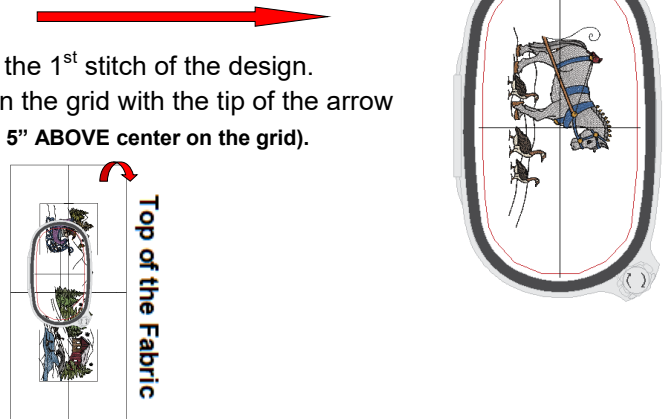

Hoop the fabric with the **arrow on the grid pointing to the green start arrow**. See **Example #7**. The drawn lines on the fabric must be parallel and perpendicular to the lines on the grid. Remove the grid from the hoop and attach the hoop to the module. **Float tear away stabilizer** (sprayed with 505) **under the attached hoop**.

### No Thread, Color #1 Placement Line.

The needle is positioned at the green start arrow see **Example #7**. Sew Color #1 without thread.

It sews following the stitched in black line (Placement Line shown in red) from the start of the end arrow.

Reposition if needed. Add a basting box then turn it off. Advance to **Color #2**.

Thread Color #2 **Silvery Grey (1972) # \_\_\_\_\_**  
Embroider the horse.

Thread Color #3 **Nutmeg (0932) # \_\_\_\_\_**  
Embroider the horse hooves, duck feet & sleigh bar.

Thread Color #4 **Foliage Rose (1911) # \_\_\_\_\_**  
Embroider the bird.

Thread Color #5 **Colonial Blue (3902) # \_\_\_\_\_**  
Embroider the horse hardware.

Thread Color #6 **Chocolate (1876) # \_\_\_\_\_**  
Embroider the geese backs.

Thread Color #7 **Muslin (0870) # \_\_\_\_\_**  
Embroider the underside of the geese.

Thread Color #8 **Pony (1233) # \_\_\_\_\_**  
Embroider the geese necks and heads.

Thread Color #9 **Gold (0704) # \_\_\_\_\_**  
Embroider the brass décor on the horse.

Thread Color #10 **Black (0020) # \_\_\_\_\_**  
Embroider the outlining.

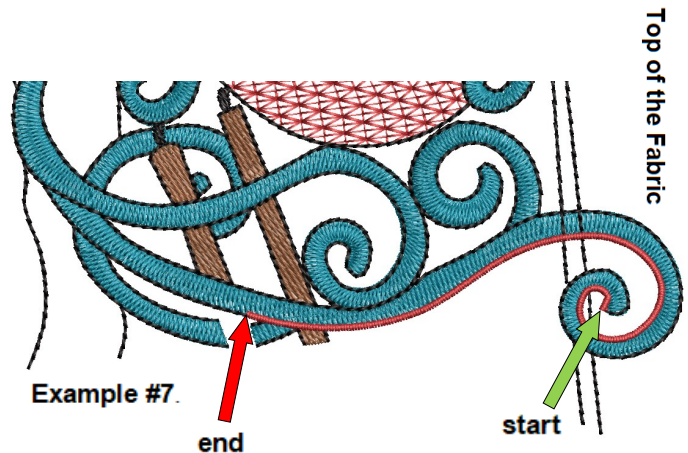

Remove the hoop from the module and the fabric from the hoop. Gently remove the stabilizer & basting stitches from the back.

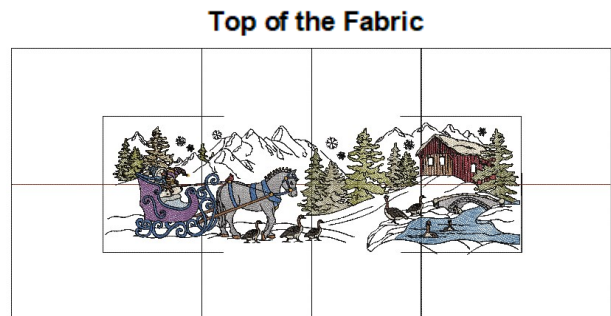

# WINTER VERSION

## Bottom Row /Winter Folder/ Making Friends

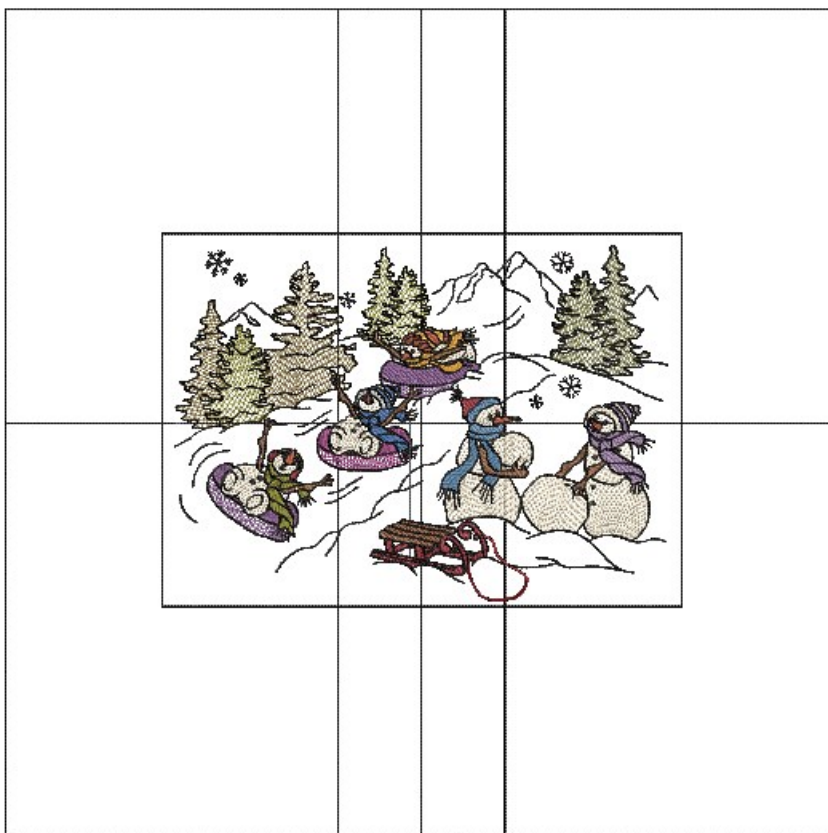

Cut Block 13" x 9 1/2"  
Finished Block 12 1/2" x 9"

### 3 Bottom Row / Winter Folder / Making Friends / Hooping #1



Select the prepared 20" x 20" Background Fabric. Select the folder with the format your machine reads. Attach the hoop and the grid (no fabric) to the module.

Larger Hoops may be able to combine Hoopings

#### Open #1 Making Friends

**Step #1** Advance to the **embroidery sewing screen** to go to the 1<sup>st</sup> stitch of the design.

**Step #2** Lower the needle, lay an arrow shaped post it note on the grid with the tip of the arrow touching the needle. (The arrow is positioned about 2 1/2" to the LEFT of center on the grid).

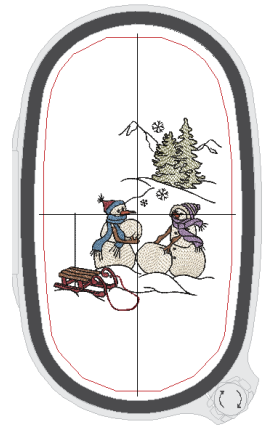

**Fabric Position:** To hoop this design the **Top of the Fabric** is **positioned at the top** of the hoop.

See **Example #1** below for **1st stitch** position.

Top of the Fabric

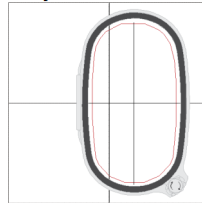

Hoop the fabric with the **arrow on the grid pointing to the Center Crosshair on the FABRIC**.

See **Example #1**. The drawn lines on the fabric must be parallel and perpendicular to the lines on the grid.

Remove the grid from the hoop and attach the hoop to the module.

**Float tear away stabilizer** (sprayed with 505) **under the attached hoop, MANDATORY!**

No Thread, Color #1 **Placement Line**. The needle is positioned over the Center Crosshair **on the fabric**. See green start arrow in **Example #1**. Sew Color #1 without thread.

**How to sew without thread:** use the **Broken Thread** or **Advance Stitch** icon!! See **Tips for Successful Embroidery**

It sews from the start arrow, downward following the drawn line, to the end arrow. Reposition if needed to follow the line. Add a basting box, sew it out then turn it off. Advance to **Color #2**.

Thread Color #2 **Moss Green (5934) # \_\_\_\_\_**

Embroider the trees.

Thread Color #3 **Muslin (0870) # \_\_\_\_\_**

Embroider the snowmen.

Thread Color #4 **Foliage Rose (1911) # \_\_\_\_\_**

Embroider the knit hat, sled rails and rope handle.

Thread Color #5 **Laguna (3810) # \_\_\_\_\_**

Embroider the scarf and hat trim.

Thread Color #6 **Dark Rust (1335) # \_\_\_\_\_**

Embroider the noses.

Thread Color #7 **Pony (1233) # \_\_\_\_\_**

Embroider the sled slats.

Thread Color #8 **Wild Iris (2830) # \_\_\_\_\_**

Embroider the scarf and hat stripes.

Thread Color #9 **Nutmeg (0932) # \_\_\_\_\_**

Embroider the arms.

Thread Color #10 **Black (0020) # \_\_\_\_\_**

Embroider the outlining, snowflakes & mountains.

Top of the Fabric

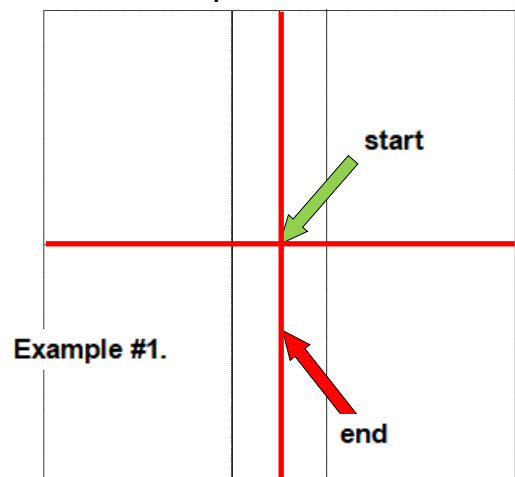

Remove the hoop from the module and the fabric from the hoop.

Gently remove the stabilizer & basting stitches from the back.

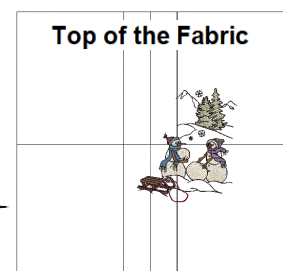



### 3 Bottom Row / Winter Folder / Making Friends / Hooping #2

Attach the hoop and the grid (no fabric) to the module. 

#### Open #2 Trees

**Step #1** Advance to the **embroidery sewing screen** to go to the 1<sup>st</sup> stitch of the design.

**Step #2** Lower the needle, lay an arrow shaped post it note on the grid with the tip of the arrow touching the needle. (The arrow is positioned about 2" to the LEFT & 3" BELOW center on the grid).

(Refer to "Tips for Successful Embroidery to get to the 1st stitch of the design for Brother, Babylock, & Janome.)

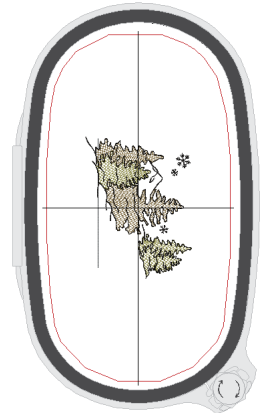

**Fabric Position:** To hoop this design the **Top of the Fabric** is rotated to the right of the hoop. 

See **Example #2** below for 1st stitch position.

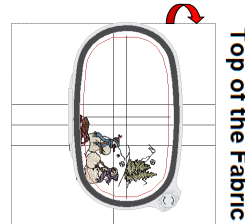

Hoop the fabric with the **arrow on the grid pointing to the Center Crosshair on the FABRIC.**

See **Example #2.** The drawn lines on the fabric must be parallel and perpendicular to the lines on the grid.

Remove the grid from the hoop and attach the hoop to the module.

**Float tear away stabilizer** (sprayed with 505) **under the attached hoop, MANDATORY!**

No Thread, Color #1 **Placement Line.** The needle is positioned over the Center Crosshair **on the fabric.** See green start arrow in **Example #2.** Sew Color #1 without thread.

**How to sew without thread: use the Broken Thread or Advance Stitch icon!! See Tips for Successful Embroidery**

It sews from the start arrow, upward following the drawn line, to the end arrow. Reposition if needed to follow the line. Add a basting box, sew it out then turn it off.

Advance to **Color #2.**

Thread Color #2 **Yellowgreen (6043) # \_\_\_\_\_**  
Embroider the trees.

Thread Color #3 **Moss (0345) # \_\_\_\_\_**  
Embroider the trees.

Thread Color #4 **Black (0020) # \_\_\_\_\_**  
Embroider the outlining, snowflakes & mountains.

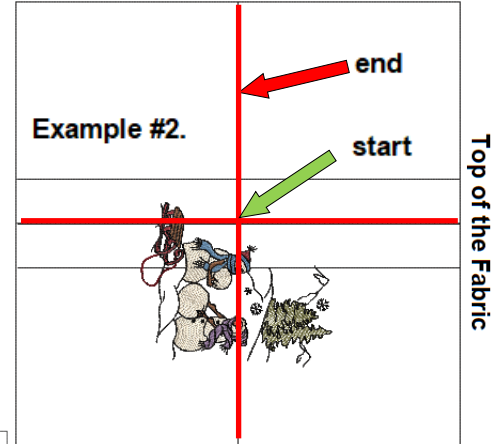

Remove the hoop from the module and the fabric from the hoop. Gently remove the stabilizer & basting stitches from the back.

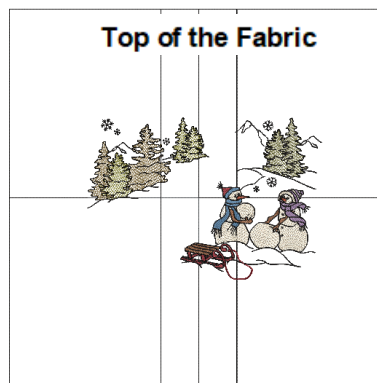

### 3 Bottom Row / Winter Folder / Making Friends Folder / Hooping #3

Select the prepared 20" x 20" Background Fabric. Select the folder with the format your machine reads. Attach the hoop and the grid (no fabric) to the module.

#### Open #3 Tubers

**Step #1** Advance to the **embroidery sewing screen** to go to the 1<sup>st</sup> stitch of the design.

**Step #2** Lower the needle, lay an arrow shaped post it note on the grid with the tip of the arrow touching the needle. (The arrow is positioned slightly to the left & 1 1/2" BELOW center on the grid)

**Fabric Position:** To hoop this design the **Top of the Fabric is rotated to the right** of the hoop. See **Example #3 below** for 1st stitch position.

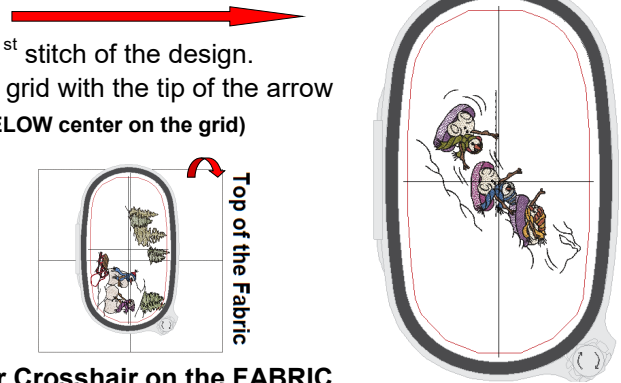

Hoop the fabric with the **arrow on the grid pointing to the Center Crosshair on the FABRIC**. See **Example #3**. The drawn lines on the fabric must be parallel and perpendicular to the lines on the grid. Remove the grid from the hoop and attach the hoop to the module.

**Float tear away stabilizer** (sprayed with 505) **under the attached hoop, MANDATORY!**

No Thread, Color #1 **Placement Line**. The needle is positioned over the Center Crosshair **on the fabric**. See green start arrow in **Example #3**. Sew Color #1 without thread.

**How to sew without thread:** use the Broken Thread or Advance Stitch icon!! See **Tips for Successful Embroidery**

It sews from the start arrow, upward following the drawn line, to the end arrow (shown in red).

Reposition if needed to follow the line. Add a basting box, sew it out then turn it off. Advance to **Color #2**.

- Thread Color #2 **Muslin (0870) # \_\_\_\_\_**  
Embroider the snowmen (sews close to tree).
- Thread Color #3 **Colonial Blue (3902) # \_\_\_\_\_**  
Embroider the scarf and hat stripes.
- Thread Color #4 **Dark Rust (1335) # \_\_\_\_\_**  
Embroider the noses & stripes on the hat (sews over tree).
- Thread Color #5 **Orchid (2810) # \_\_\_\_\_**  
Embroider the tubes.
- Thread Color #6 **Yellowgreen (6043) # \_\_\_\_\_**  
Embroider the knit hat and scarf.
- Thread Color #7 **Peony (2723) # \_\_\_\_\_**  
Embroider the center tube.
- Thread Color #8 **Nutmeg (0932) # \_\_\_\_\_**  
Embroider the arms.
- Thread Color #9 **Foliage Rose (1911) # \_\_\_\_\_**  
Embroider the ear muffs.
- Thread Color #10 **Gold (0704) # \_\_\_\_\_**  
Embroider the knit hat and scarf.
- Thread Color #11 **Rough Sea (4332) # \_\_\_\_\_**  
Embroider the trim on the center hat.
- Thread Color #12 **Black (0020) # \_\_\_\_\_**  
Embroider the outlining & mountains.

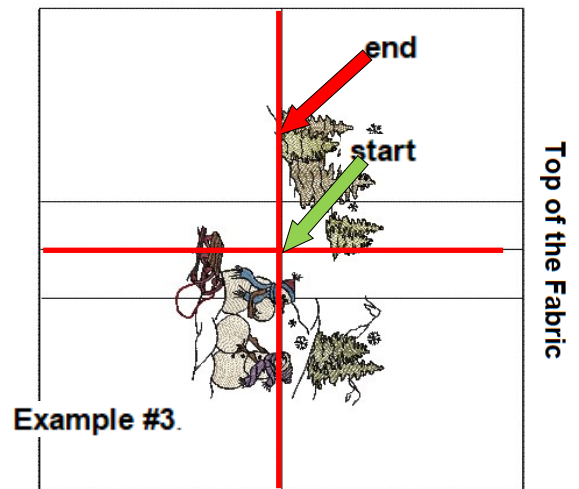

Remove the hoop from the module and the fabric from the hoop. Gently remove the stabilizer & basting stitches from the back.

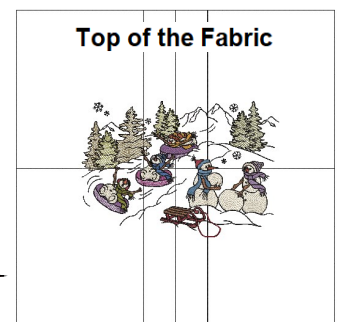

# WINTER VERSION

## Bottom Row / Winter Folder / Ice Skating

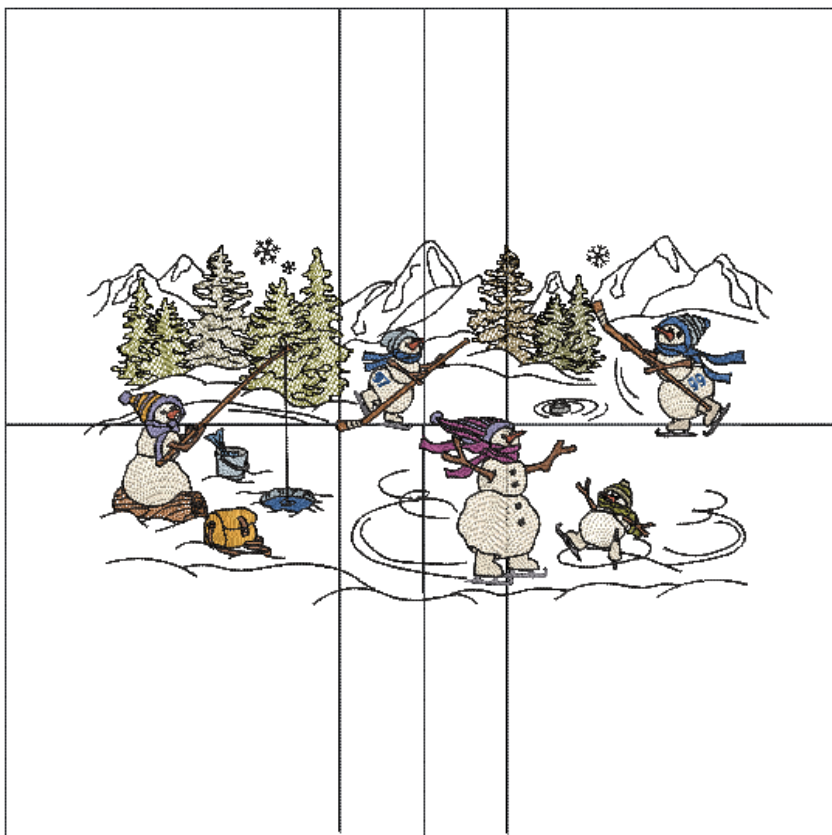

Cut Block 16 1/2" x 9 1/2"  
Finished Block 16" x 9"

### 3 Bottom Row / Winter Folder / Ice Skating Folder / Hooping #1



Select the prepared 20" x 20" Background Fabric. Select the folder with the format your machine reads. Attach the hoop and the grid (no fabric) to the module.

Larger hoops may be able to combine Hoopings

#### Open #1 Skaters

**Step #1** Advance to the **embroidery sewing screen** to go to the 1<sup>st</sup> stitch of the design.

**Step #2** Lower the needle, lay an arrow shaped post it note on the grid with the tip of the arrow touching the needle. (The arrow is positioned about 1" to the LEFT of center on the grid).

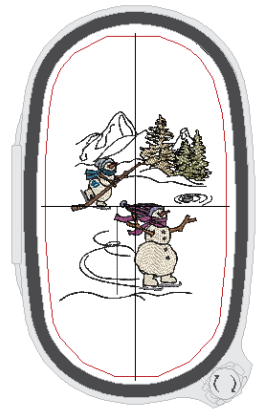

**Fabric Position:** To hoop this design the **Top of the Fabric** is **positioned at the top** of the hoop.

See **Example #1** below for **1st stitch** position.

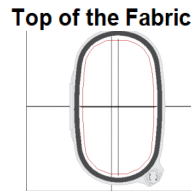

Hoop the fabric with the **arrow on the grid pointing to the Center Crosshair on the FABRIC**.

See **Example #1**. The drawn lines on the fabric must be parallel and perpendicular to the lines on the grid.

Remove the grid from the hoop and attach the hoop to the module.

**Float tear away stabilizer** (sprayed with 505) **under the attached hoop, MANDATORY!**

No Thread, Color #1 **Placement Line**. The needle is positioned over the **Center Crosshair on the FABRIC**. See green start arrow in **Example #1**. Sew Color #1 without thread.

It sews from the start arrow, downward following the drawn line, to the end arrow. Reposition if needed to follow the line. Add a basting box, sew it out then turn it off. Advance to **Color #2**.

- Thread Color #2 **Muslin (0870) #** \_\_\_\_\_  
Embroider the snowmen.
- Thread Color #3 **Moss (0345) #** \_\_\_\_\_  
Embroider the left tree.
- Thread Color #4 **Winter Frost (3750) #** \_\_\_\_\_  
Embroider the knit hat.
- Thread Color #5 **Peony (2723) #** \_\_\_\_\_  
Embroider the hat and scarf.
- Thread Color #6 **Moss Green (5934) #** \_\_\_\_\_  
Embroider the right trees.
- Thread Color #7 **Dark Rust (1335) #** \_\_\_\_\_  
Embroider the noses.
- Thread Color #8 **Pony (1233) #** \_\_\_\_\_  
Embroider the hockey stick.
- Thread Color #9 **Dawn of Violet (3130) #** \_\_\_\_\_  
Embroider the knit hat stripes.
- Thread Color #10 **Nutmeg (0932) #** \_\_\_\_\_  
Embroider the arms.
- Thread Color #11 **Leadville (0112) #** \_\_\_\_\_  
Embroider the skate blades.
- Thread Color #12 **Colonial Blue (3902) #** \_\_\_\_\_  
Embroider the scarf and number.
- Thread Color #13 **Sterling (0142) #** \_\_\_\_\_  
Embroider the puck.
- Thread Color #14 **Black (0020) #** \_\_\_\_\_  
Embroider the outlining.

Remove the hoop from the module and the fabric from the hoop.  
Gently remove the stabilizer & basting stitches from the back.

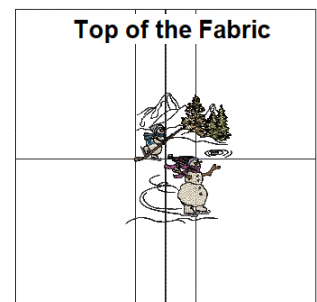
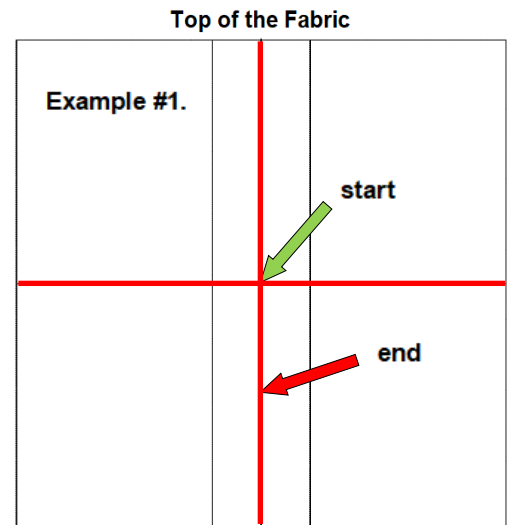



### 3 Bottom Row / Winter Folder / Ice Skating Folder / Hooping #2

Attach the hoop and the grid (no fabric) to the module.

#### Open #2 Fishing

**Step #1** Advance to the **embroidery sewing screen** to go to the 1<sup>st</sup> stitch of the design.

**Step #2** Lower the needle, lay an arrow shaped post it note on the grid with the tip of the arrow touching the needle. (The arrow is positioned about 2 1/2" to the RIGHT just below center on the grid).

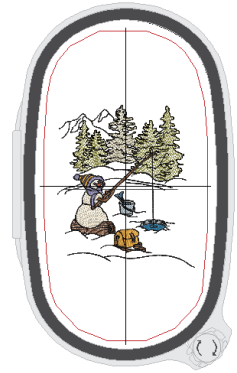

**Fabric Position:** To hoop this design the **Top of the Fabric** is **positioned at the top** of the hoop. See **Example #2** below for **1st stitch** position.

Top of the Fabric

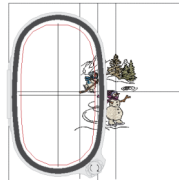

Hoop the fabric with the **arrow on the grid pointing to the Crosshair 2" to the left of the Center Crosshair on the FABRIC**. See **Example #2**. The drawn lines on the fabric must be parallel and perpendicular to the lines on the grid. Remove the grid from the hoop and attach the hoop to the module.

**Float tear away stabilizer** (sprayed with 505) **under the attached hoop, MANDATORY!**

No Thread, Color #1 **Placement Line**. The needle is positioned over the **Crosshair 2" to the left of Center on the a FABRIC**. See green start arrow in **Example #2**. Sew Color #1 without thread.

**How to sew without thread: use the Broken Thread or Advance Stitch icon!! See Tips for Successful Embroidery**

It sews from the start arrow, left following the drawn line, to the end arrow. Reposition if needed to follow the line. Add a basting box, sew it out then turn it off. Advance to **Color #2**.

- Thread Color #2 **Muslin (0870) # \_\_\_\_\_**  
Embroider the snowman.
- Thread Color #3 **Dawn of Violet (3130) # \_\_\_\_\_**  
Embroider the knit hat and scarf.
- Thread Color #4 **Colonial Blue (3902) # \_\_\_\_\_**  
Embroider the water.
- Thread Color #5 **Yellowgreen (6043) # \_\_\_\_\_**  
Embroider the outer trees.
- Thread Color #6 **Dark Rust (1335) # \_\_\_\_\_**  
Embroider the nose.
- Thread Color #7 **Army Drab (0453) # \_\_\_\_\_**  
Embroider the center tree.
- Thread Color #8 **Gold (0704) # \_\_\_\_\_**  
Embroider creel fishing basket & hat stripes.
- Thread Color #9 **Sterling (0142) # \_\_\_\_\_**  
Embroider the inside of bucket and handle.
- Thread Color #10 **Laguna (3810) # \_\_\_\_\_**  
Embroider the fish.
- Thread Color #11 **Pony (1233) # \_\_\_\_\_**  
Embroider the fishing pole, log and strap.
- Thread Color #12 **Winter Frost (3750) # \_\_\_\_\_**  
Embroider the bucket and edge of fishing hole.
- Thread Color #13 **Nutmeg (0932) # \_\_\_\_\_**  
Embroider the arms and pouch straps.
- Thread Color #14 **Black (0020) # \_\_\_\_\_**  
Embroider the outlining.

Top of the Fabric

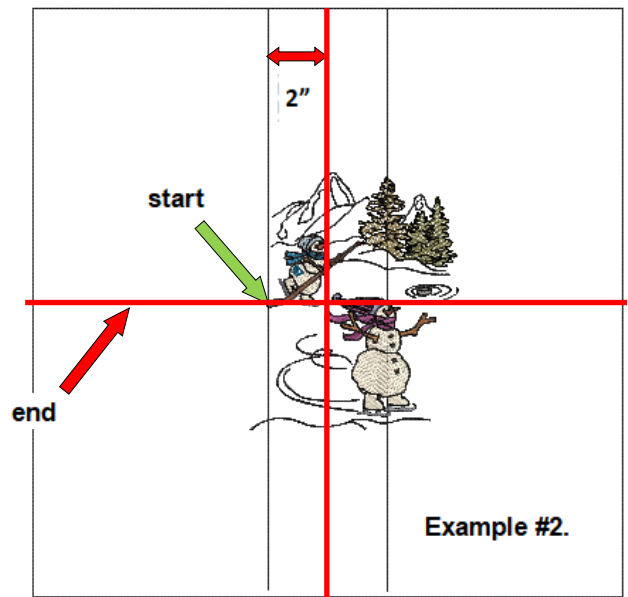

Top of the Fabric

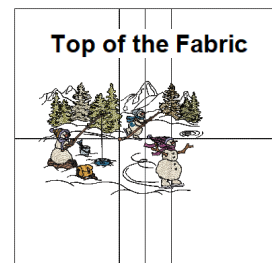

Remove the hoop from the module and the fabric from the hoop. Gently remove the stabilizer & basting stitches from the back.



### 3 Bottom Row / Winter Folder / Ice Skating / Hooping #3

Attach the hoop and the grid (no fabric) to the module.

#### Open #3 Hockey

**Step #1** Advance to the **embroidery sewing screen** to go to the 1<sup>st</sup> stitch of the design.

**Step #2** Lower the needle, lay an arrow shaped post it note on the grid with the tip of the arrow touching the needle. (The arrow is positioned about 3" to the LEFT of center on the grid).

(Refer to "Tips for Successful Embroidery" about getting to the 1st stitch of the design for **Brother, Babylock, & Janome** machines)

**Fabric Position:** To hoop this design the **Top of the Fabric** is **positioned at the top** of the hoop.

See **Example #3** below for **1st stitch** position.

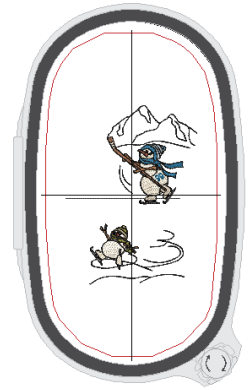

Top of the Fabric

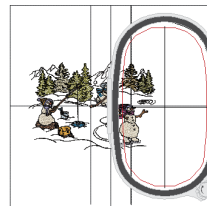

Hoop the fabric with the **arrow on the grid pointing to the Crosshair 2" to the RIGHT of Center on the FABRIC**. See **Example #3**. The drawn lines on the fabric must be parallel and perpendicular to the lines on the grid. Remove the grid from the hoop and attach the hoop to the module.

**Float 2 pieces of tear away stabilizer** (sprayed with 505) **under the attached hoop**, MANDATORY!

No Thread, Color #1 **Placement Line**. The needle is positioned over the **Crosshair 2" to the RIGHT of Center on the FABRIC**. See green start arrow in **Example #3**. Sew Color #1 without thread.

**How to sew without thread: use the Broken Thread or Advance Stitch icon!! See Tips for Successful Embroidery**

It sews from the start arrow, to the right following the drawn line, to the end arrow. Reposition if needed to follow the line. Add a basting box, sew it out then turn it off. Advance to **Color #2**.

Thread Color #2 **Muslin (0870) #** \_\_\_\_\_  
Embroider the snowmen.

Thread Color #3 **Army Drab (0453) #** \_\_\_\_\_  
Embroider the knit hat trim.

Thread Color #4 **Winter Frost (3750) #** \_\_\_\_\_  
Embroider the knit hat.

Thread Color #5 **Leadville (0112) #** \_\_\_\_\_  
Embroider the skate blades.

Thread Color #6 **Colonial Blue (3902) #** \_\_\_\_\_  
Embroider the hat trim, scarf and numbers.

Thread Color #7 **Nutmeg (0932) #** \_\_\_\_\_  
Embroider the arms.

Thread Color #8 **Yellowgreen (6043) #** \_\_\_\_\_  
Embroider the scarf and hat.

Thread Color #9 **Dark Rust (1335) #** \_\_\_\_\_  
Embroider the noses.

Thread Color #10 **Pony (1233) #** \_\_\_\_\_  
Embroider the hockey stick.

Thread Color #11 **Black (0020) #** \_\_\_\_\_  
Embroider the outlining.

Remove the hoop from the module and the fabric from the hoop. Gently remove the stabilizer & basting stitches from the back.



Top of the Fabric

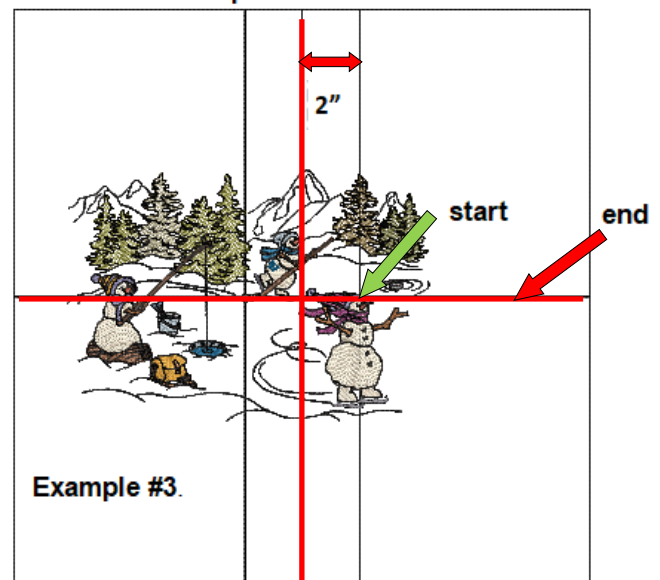

Top of the Fabric

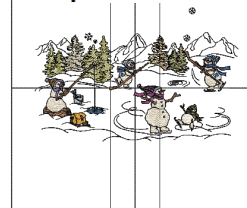

## #4 Embroidered Borders

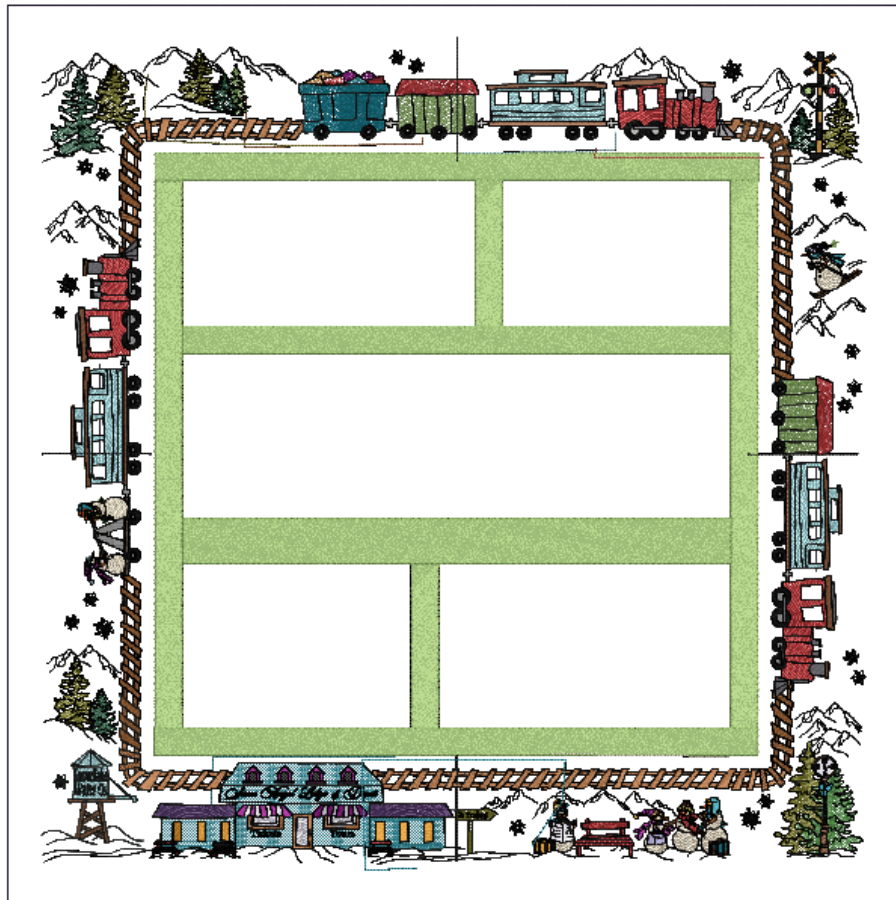

# EMBROIDERED BORDERS



## Fabric Preparation for Embroidered Borders:

**44" Wide x 66 +/-" Long**

Follow the Fabric Preparation Instructions on **page #6**. (Must use Terial Magic & Shape Flex)

### Cutting Instructions:

If you have not already cut the Border Fabric do so now.

Cut the remaining prepared fabric  
in half lengthwise:

Cut down the long **center** of the  
66 +/-" **length** of the fabric.

The width will be 22"+/- depending on width of your fabric.

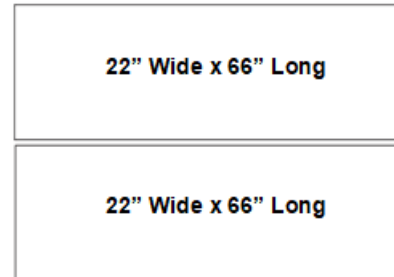

**(2) 22" Wide x 66+/-" Long**

## Marking Instructions

### Mark the Fabric:

On the front side of the fabric (pen with removable ink) mark a

**Horizontal & Vertical line, centered on the fabric** (See **Mark a Center Crosshair** pic)

(aka=center crosshair / shown in red) use a square ruler to mark the **lines to ensure a 90° center**.

See my **YouTube** demo. **YouTube / ClaudiasCreationsaz / Marking the Fabric**

(be sure to subscribe & click on the bell to be notified of new videos)

Mark long **horizontal lines 5 ½"** above & below the **Center Horizontal Line**. (See dotted lines in pic below)

All lines must be **parallel & perpendicular** to each other

**(90° angles)**. These lines are the full length and width of the fabric.

Write the words **Top Bottom Left & Right** accordingly at the top end of each fabric strip. See picture below.

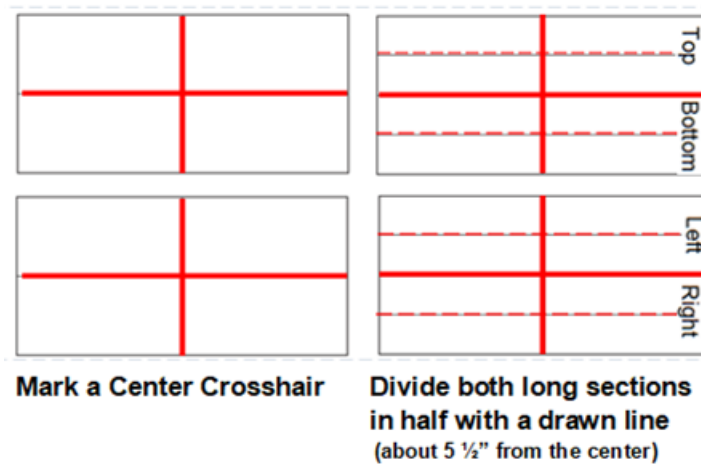



# Isacord Thread Conversion Christmas to Winter

## Christmas Colors (=c)

## Winter Colors (=w)

### Blues

### Blues

4240 Spearmint

3750 Winter Frost

4332 Rough Sea

4010 Caribbean Blue

3810 Laguna

4116 Dark Teal

3902 Colonial Blue



### Purples/Pinks

### Purples/Pinks

3130 Dawn of Violet

3130 Dawn of Violet

2830 Wild Iris

2721 Very Berry

2723 Peony

2702 Grape Jelly

2810 Orchid



### Greens

### Greens

5610 Bright Mint

0453 Army Drab

6043 Yellowgreen

6043 Yellowgreen

5510 Emerald

0345 Moss

5324 Bright Green

5934 Moss Green



### Browns

### Browns

0932 Nutmeg

0932 Nutmeg

1233 Pony

1233 Pony

1876 Chocolate

1876 Chocolate



### Greys

### Greys

1972 Silvery Grey

1972 Silvery Grey

0142 Sterling

0142 Sterling

0112 Leadville

0112 Leadville



### Yellow/Golds

### Yellow/Golds

0811 Candlelight

0704 Gold

0824 Liberty Gold

0721 Antique



### Red/Oranges

### Red/Oranges

1304 Red Pepper

1335 Dark Rust

1800 Wildfire

1911 Foliage Rose



## Embroidered Borders (pages #58-#89)

The Colors will appear like this:

Green (c5610 w0453)

Green = Color Family  
(look at the green threads)

c5610 = c shows Christmas Colors  
w0453 = w shows Winter Colors

If the instructions show only one  
Thread Color, use it!

That color is used in both versions.  
Sterling (0142) # \_\_\_\_\_

The thread colors on the SCREEN  
will be digitized in the  
Christmas Colors:

for Winter Colors  
READ the instructions.

Green (c5610 w0453)

**Black, Whites &  
Muslin Colors  
are the same in both  
versions.**

## 4 Borders Folder / #1 Top Border / Hooping 1

Use the prepared and marked fabric for the **Top & Bottom Borders**

Attach the hoop and the grid (no fabric) to the module.

### Open #1 Center Car



**Step #1** Advance to the **embroidery sewing screen** to go to the 1<sup>st</sup> stitch of the design.

**Step #2** Lower the needle, lay an arrow shaped post it note on the grid with the tip of the arrow touching the needle. (The arrow is positioned about 2" below & slightly to the RIGHT of center on the grid.)

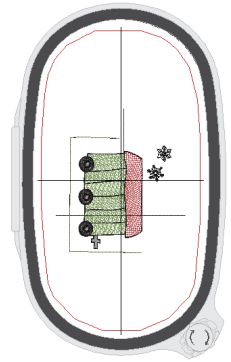

### Fabric Position:



To hoop this design the **Top of the Fabric** is positioned at the **TOP** of the hoop.

See **Example #1** below for 1st stitch position.

Top of the Fabric



Hoop the fabric with the **arrow on the grid pointing to the green start arrow** see **Example #1**. The drawn lines on the fabric must be parallel and perpendicular to the lines on the grid. **REMOVE** the grid from the hoop and attach the hoop to the module. **Float one piece of heavy weight tear away stabilizer** (sprayed with 505) **under the attached hoop**.

Designs open on the screen in Christmas Colors: use instructions for **Winter Colors Green (c5610 w0453)** see p #57

No Thread Color #1 **Placement Line**. The needle is positioned at the green start arrow see **Example #1**. The arrow on the grid points to the **Center Crosshair on the FABRIC**. Sew Color #1 without thread:

**How to sew without thread: use the Broken Thread or Advance Stitch icon!! See Tips for Successful Embroidery** it sews from the start arrow upward to the end arrow following the drawn line. Re-position if needed to follow the line. Add a basting box, sew it out then turn it off. Advance to **Color #2**.

- Thread Color #2 **Green (c5610 w0453) # \_\_\_\_\_**  
Embroider the basting stitches & lower part of the car.
- Thread Color #3 **Red (c1800 w1911) # \_\_\_\_\_**  
Embroider the car's roof.
- Thread Color #4 **Sterling (0142) # \_\_\_\_\_**  
Embroider the center of the wheels and brackets.
- Thread Color #5 **Black (0020) # \_\_\_\_\_**  
Embroider the outlining and **Center Placement Line**.

Top of the Fabric

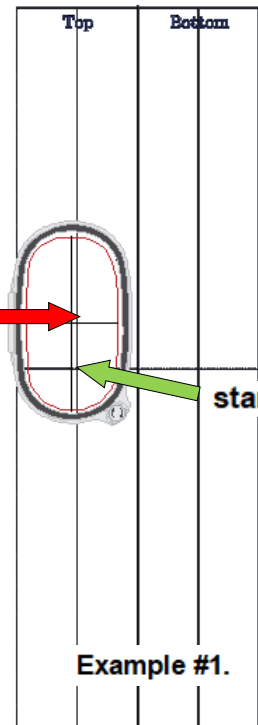

Remove the hoop from the module and the fabric from the hoop.  Gently remove the stabilizer from the back.

Remove the basting stitches...but

Do NOT remove the **Center Placement Line**  
Use this Line for centering the Border Strip to quilt top.  
If the line is accidentally removed please refer to p.83 for position of the Center Placement Line.



Example #1.

## 4 Borders Folder / #1 Top Border / Hooping 2

Attach the hoop and the grid (no fabric) to the module.

### Open #2 Gift Car

**Step #1** Advance to the **embroidery sewing screen** to go to the 1<sup>st</sup> stitch of the design.  
**Step #2** Lower the needle, lay an arrow shaped post it note on the grid with the tip of the arrow touching the needle. (The arrow is positioned about 3" BELOW & ½ to the RIGHT of center on the grid.)

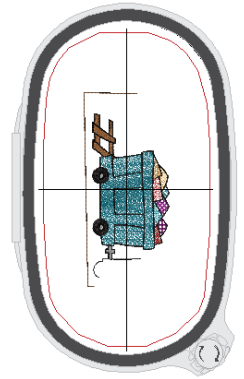

### Fabric Position:

To hoop this design the **Top of the Fabric** is positioned at the **TOP** of the hoop. See **Example #2** below for 1st stitch position.

Top of the Fabric



Hoop the fabric with the **arrow on the grid pointing to the green start arrow** see **Example #2**. The drawn lines on the fabric must be parallel and perpendicular to the lines on the grid. **REMOVE** the grid from the hoop and attach the hoop to the module. **Float one piece of heavy weight tear away stabilizer** (sprayed with 505) **under the attached hoop**.

No Thread Color #1 **Placement Line**. The needle is positioned at the green start arrow see **Example #2**. The arrow on the grid points to the **intersection between the roof and car**. Sew Color #1 without thread: it sews from the start arrow to the left to the end arrow following the outline of the edge of the car and wheel.

Re-position if needed to follow the outline.  
 Add a basting box, sew it out then turn it off.  
 Advance to **Color #2**.

- Thread Color #2 **Nutmeg (0932) # \_\_\_\_\_**  
Embroider the basting stitches & tracks.
- Thread Color #3 **Blue (c4116 w3902) # \_\_\_\_\_**  
Embroider the gift car.
- Thread Color #4 **Red (c1800 w1911) # \_\_\_\_\_**  
Embroider the packages.
- Thread Color #5 **Blue (c4010 w3810) # \_\_\_\_\_**  
Embroider the packages.
- Thread Color #6 **Yellow (c0811 w0704) # \_\_\_\_\_**  
Embroider the packages.
- Thread Color #7 **Purple (c2721 w2723) # \_\_\_\_\_**  
Embroider the packages.
- Thread Color #8 **Sterling (0142) # \_\_\_\_\_**  
Embroider the center of the wheels and bracket.
- Thread Color #9 **Black (0020) # \_\_\_\_\_**  
Embroider the outlining.

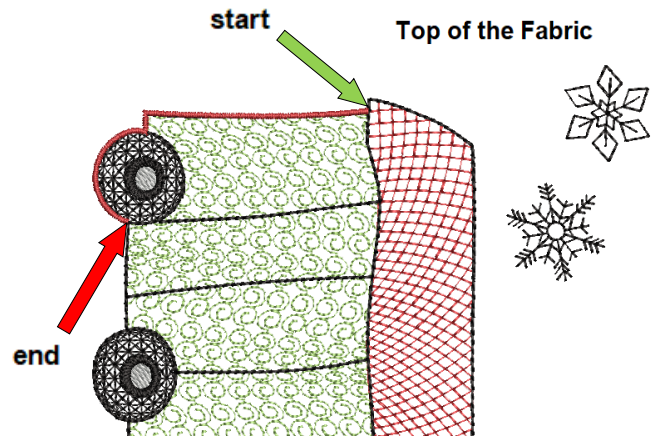

**Example #2.**

Remove the hoop from the module and the fabric from the hoop.  
 Gently remove the stabilizer from the back.

Remove the basting stitches.



## 4 Borders Folder / #1 Top Border / Hooping 3

Attach the hoop and the grid (no fabric) to the module.

### Open #3 Trees

**Step #1** Advance to the **embroidery sewing screen** to go to the 1<sup>st</sup> stitch of the design.

**Step #2** Lower the needle, lay an arrow shaped post it note on the grid with the tip of the arrow touching the needle. (The arrow is positioned about 3½" BELOW & ½" to the RIGHT of center on the grid.)

Top of the Fabric



### Fabric Position:

To hoop this design the **Top of the Fabric** is positioned at the **TOP** of the hoop.

See **Example #3** below for **1st stitch** position.

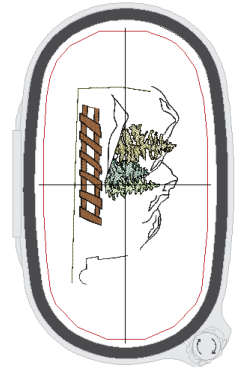

Hoop the fabric with the **arrow on the grid pointing to the green start arrow** see **Example #3**. The drawn lines on the fabric must be parallel and perpendicular to the lines on the grid. **REMOVE** the grid from the hoop and attach the hoop to the module. **Float one piece of heavy weight tear away stabilizer** (sprayed with 505) **under the attached hoop**.

No Thread Color #1 **Placement Line**. The needle is positioned at the green start arrow see **Example #3**. The arrow **on the grid points to the intersection between the side of the car and the lip of the car**.

Sew Color #1 without thread: it sews from the start arrow to the left to the end arrow following the outline of the car & wheel.

Re-position if needed to follow the line.

Add a basting box, sew it out then turn it off. Advance to **Color #2**.

Thread Color #2 **Yellowgreen (6043) #** \_\_\_\_\_

Embroider the basting stitches & upper tree.

Thread Color #3 **Green (c5610 w0453) #** \_\_\_\_\_

Embroider the lowest tree.

Thread Color #4 **Green (c5324 w5934) #** \_\_\_\_\_

Embroider the middle tree.

Thread Color #5 **Nutmeg (0932) #** \_\_\_\_\_

Embroider the railroad track.

Thread Color #6 **Black (0020) #** \_\_\_\_\_

Embroider the outlining.

Remove the hoop from the module and the fabric from the hoop.

Gently remove the stabilizer from the back.

Remove the all basting stitches.

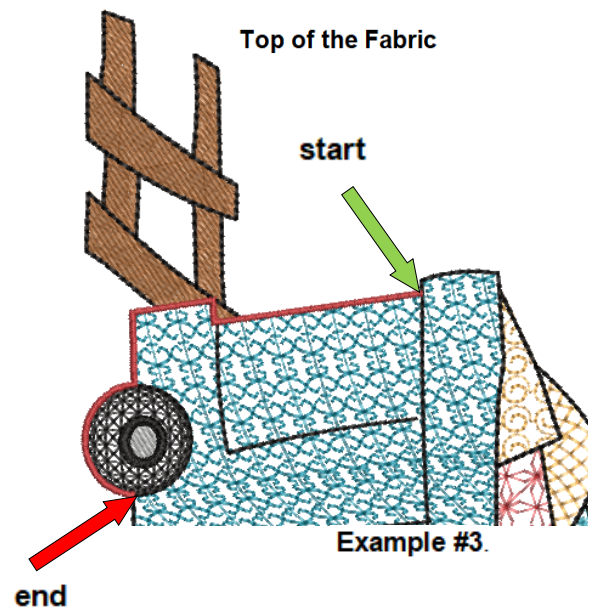
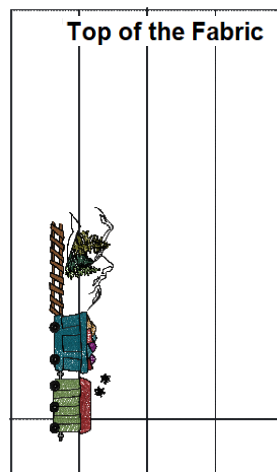



## 4 Borders Folder / #1 Top Border / Hooping 4

Attach the hoop and the grid (no fabric) to the module.

### Open #4 Passenger Car



**Step #1** Advance to the **embroidery sewing screen** to go to the 1<sup>st</sup> stitch of the design.

**Step #2** Lower the needle, lay an arrow shaped post it note on the grid with the tip of the arrow touching the needle. (The arrow is positioned about 3 1/2" ABOVE & 3/4" to the RIGHT of center on the grid.)

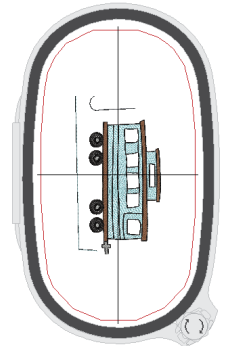

### Fabric Position:



To hoop this design the **Top of the Fabric** is positioned at the **TOP** of the hoop.

See **Example #4** below for **1st stitch** position.

Top of the Fabric

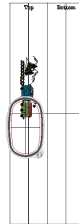

Hoop the fabric with the **arrow on the grid pointing to the green start arrow** see **Example #4**. The drawn lines on the fabric must be parallel and perpendicular to the lines on the grid. **REMOVE** the grid from the hoop and attach the hoop to the module. **Float one piece of heavy weight tear away stabilizer** (sprayed with 505) **under the attached hoop**.

No Thread Color #1 **Placement Line**. The needle is positioned at the green start arrow see **Example #4**. The arrow on the grid points to the **intersection between the car and roof**. Sew Color #1 without thread: it sews from the start arrow to the right to the end arrow following the outline of the car and wheel.

Re-position if needed to follow the line.

Add a basting box then turn it off. Advance to **Color #2**.

Thread Color #2 **Blue (c4240 w3750) # \_\_\_\_\_**  
Embroider the basting stitches & passenger car.

Thread Color #3 **Pony (1233) # \_\_\_\_\_**  
Embroider the car trim.

Thread Color #4 **Sterling (0142) # \_\_\_\_\_**  
Embroider the center of the wheels.

Thread Color #5 **Black (0020) # \_\_\_\_\_**  
Embroider the outlining.

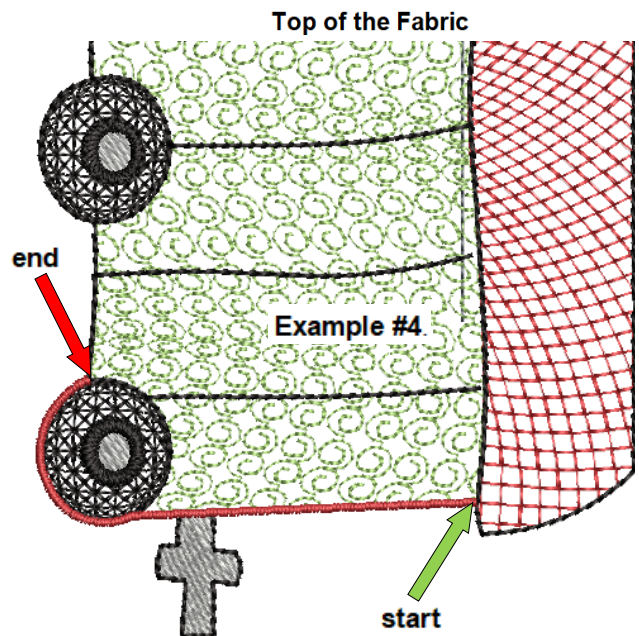

Top of the Fabric

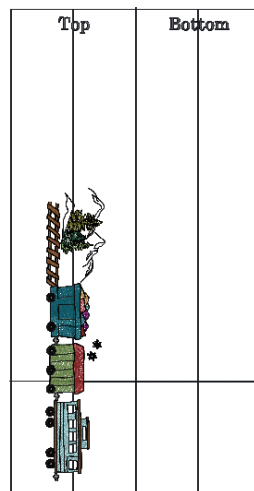

Remove the hoop from the module and the fabric from the hoop.



Gently remove the stabilizer from the back.

Remove all the basting stitches.

## 4 Borders Folder / #1 Top Border / Hooping 5

Attach the hoop and the grid (no fabric) to the module.

### Open #5 Engine

**Step #1** Advance to the **embroidery sewing screen** to go to the 1<sup>st</sup> stitch of the design.

**Step #2** Lower the needle, lay an arrow shaped post it note on the grid with the tip of the arrow touching the needle. (The arrow is positioned about 3" ABOVE & 1/2" to the RIGHT of center on the grid.)

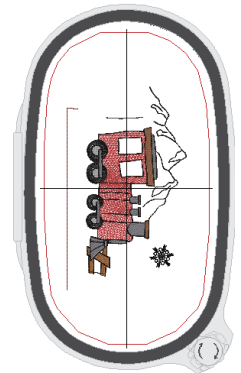

### Fabric Position:

To hoop this design the **Top of the Fabric** is positioned at the **TOP** of the hoop.

See **Example #5** below for 1st stitch position.

Top of the Fabric

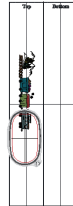

Hoop the fabric with the **arrow on the grid pointing to the green start arrow** see **Example #5**. The drawn lines on the fabric must be parallel and perpendicular to the lines on the grid. **REMOVE** the grid from the hoop and attach the hoop to the module. **Float one piece of heavy weight tear away stabilizer** (sprayed with 505) **under the attached hoop**.

No Thread Color #1 **Placement Line**. The needle is positioned at the green start arrow see **Example #5**. The arrow on the grid points to the **intersection between the car and roof**. Sew Color #1 without thread: it sews from the start arrow left to the end arrow following the outline of the car. (Shown in red) Re-position if needed to follow the line. Add a basting box then turn it off. Advance to **Color #2**.

Top of the Fabric

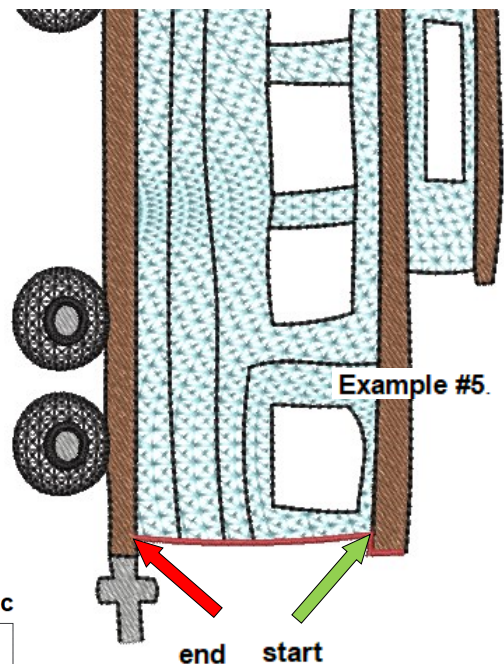

Thread Color #2 **Red (c1800 w1911) # \_\_\_\_\_**  
Embroider the basting stitches & Engine.

Thread Color #3 **Nutmeg (0932) # \_\_\_\_\_**  
Embroider the railroad track.

Thread Color #4 **Leadville (0112) # \_\_\_\_\_**  
Embroider the steel parts, cow catcher, & smoke stack.

Thread Color #5 **Pony (1233) # \_\_\_\_\_**  
Embroider the tops of the smoke stacks and roof.

Thread Color #6 **Sterling (0142) # \_\_\_\_\_**  
Embroider the wheels.

Thread Color #7 **Black (0020) # \_\_\_\_\_**  
Embroider the outlining.

Top of the Fabric

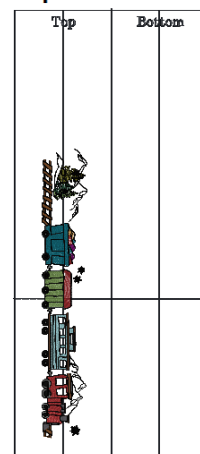

Remove the hoop from the module and the fabric from the hoop. Gently remove the stabilizer from the back.

# 4 Borders Folder / #2 Bottom Border Folder / Hooping 1

Attach the hoop and the grid (no fabric) to the module.

## Open #1 To Trains

**Step #1** Advance to the **embroidery sewing screen** to go to the 1<sup>st</sup> stitch of the design.

**Step #2** Lower the needle, lay an arrow shaped post it note on the grid with the tip of the arrow touching the needle. (The arrow is positioned about 1/2" ABOVE & 1/4" to the RIGHT of center on the grid.)

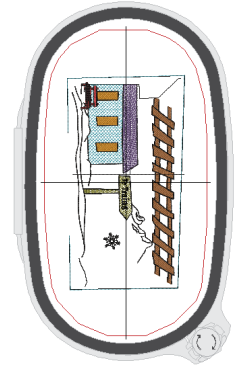

Top of the Fabric

### Fabric Position:



To hoop this design the **Top of the Fabric** is positioned at the **TOP** of the hoop.

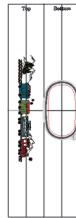

Hoop the fabric with the **arrow on the grid pointing to the green start arrow** see **Example #1**. The drawn lines on the fabric must be parallel and perpendicular to the lines on the grid. **REMOVE** the grid from the hoop and attach the hoop to the module. **Float one piece of heavy weight tear away stabilizer** (sprayed with 505) **under the attached hoop**.

No Thread Color #1 **Placement Line**. The needle is positioned at the green start arrow see **Example #1**. The arrow on the grid points to the **Center Crosshair on the FABRIC**. Sew Color #1 without thread: it sews from the start arrow straight upward to the end arrow following the drawn line. Re-position if needed to follow the line. Add a basting box, sew it out then turn it off. Advance to Color #2.

Thread Color #2 **Blue (c4010 w3810) # \_\_\_\_\_**  
Embroider the basting stitches & bottom of the lodge.

Thread Color #3 **Purple (c2702 w2810) # \_\_\_\_\_**  
Embroider the roof top.

Thread Color #4 **Gold (c0824 w0721) # \_\_\_\_\_**  
Embroider the windows.

Thread Color #5 **Red (c1800 w1911) # \_\_\_\_\_**  
Embroider the bench.

Thread Color #6 **Yellowgreen (6043) # \_\_\_\_\_**  
Embroider the sign.

Thread Color #7 **Nutmeg (0932) # \_\_\_\_\_**  
Embroider the tracks.

Thread Color #8 **Black (0020) # \_\_\_\_\_**  
Embroider the outlining &  
**Center Placement Line**

Remove the hoop from the module and the fabric from the hoop.   
Gently remove the stabilizer from the back.  
Remove the basting stitches...but

**Do NOT** remove the **Center Placement Line**  
Use this Line for centering the Border Strip to quilt top.  
If the line is accidentally removed please refer to p.83 for position of the Center Placement Line.

Top of the Fabric

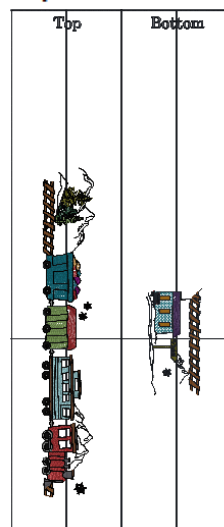

Top of the Fabric

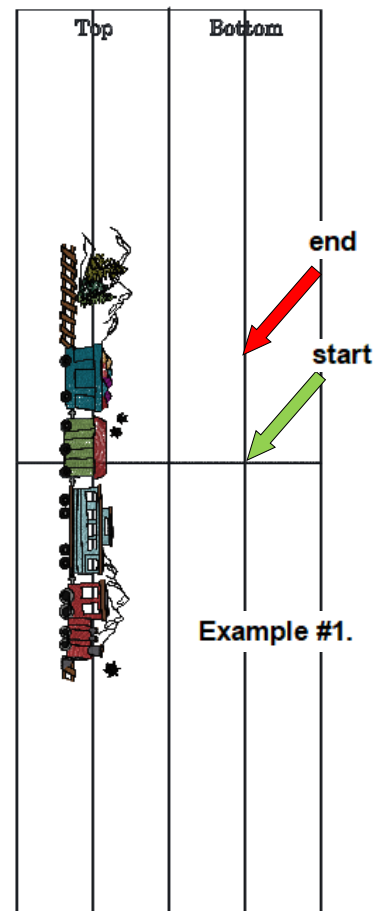

Example #1.

## 4 Borders Folder / #2 Bottom Border / Hooping 2

Attach the hoop and the grid (no fabric) to the module.

### Open #2 Travelers

**Step #1** Advance to the **embroidery sewing screen** to go to the 1<sup>st</sup> stitch of the design.

**Step #2** Lower the needle, lay an arrow shaped post it note on the grid with the tip of the arrow touching the needle. (The arrow is about 4" ABOVE & 2 to the RIGHT of center on the grid.)

### Fabric Position:

To hoop this design the **Top of the Fabric** is positioned at the **TOP** of the hoop.

Hoop the fabric with the **arrow on the grid pointing to the green start arrow** see **Example #2**.

**REMOVE** the grid from the hoop and attach the hoop to the module. **Float one piece of heavy weight tear away stabilizer** (sprayed with 505) **under the attached hoop**.

No Thread Color #1 **Placement Line**. The needle is positioned at the green start arrow see **Example #2**.

Sew Color #1 without thread: it sews from the start to end arrow following the outline of the rail.

Re-position if needed. Add a basting box, sew it out then turn it off. Advance to **Color #2**.

Thread Color #2 **Muslin (0870) # \_\_\_\_\_**  
Embroider the basting stitches & snowmen.

Thread Color #3 **Blue (c4116 w3902) # \_\_\_\_\_**  
Embroider the suitcase, scarves & hat trim.

Thread Color #4 **Gold (c0824 w0721) # \_\_\_\_\_**  
Embroider the suitcase & hat trim.

Thread Color #5 **White (0015) # \_\_\_\_\_**  
Embroider the newspaper & glove trim.

Thread Color #6 **Purple (c2721 w2723) # \_\_\_\_\_**  
Embroider the hat scarf and mittens.

Thread Color #7 **Yellow (c0811 w0704) # \_\_\_\_\_**  
Embroider the hat trim and hat.

Thread Color #8 **Red (c1800 w1911) # \_\_\_\_\_**  
Embroider the scarf, hat trim, and bench.

Thread Color #9 **Orange (c1304 w1335) # \_\_\_\_\_**  
Embroider the noses.

Thread Color #10 **Nutmeg (0932) # \_\_\_\_\_**  
Embroider the tracks, hands and arms.

Thread Color #11 **Dawn of Violet (3130) # \_\_\_\_\_**  
Embroider the purse.

Thread Color #12 **Pony (1233) # \_\_\_\_\_**  
Embroider the briefcase.

Thread Color #13 **Yellowgreen (6043) # \_\_\_\_\_**  
Embroider the knit hat.

Thread Color #14 **Chocolate (1876) # \_\_\_\_\_**  
Embroider the suitcase, briefcase straps & purse top.

Thread Color #15 **Blue (c4010 w3810) # \_\_\_\_\_**  
Embroider the dad's hat.

Thread Color #16 **Black (0020) # \_\_\_\_\_**  
Embroider the outlining & mountains.

Remove the hoop from the module and fabric from the hoop.

Gently remove the stabilizer and all the basting stitches.

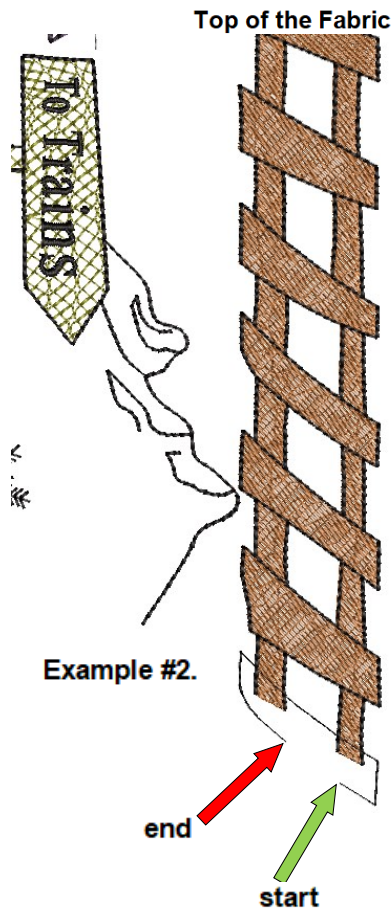

Example #2.

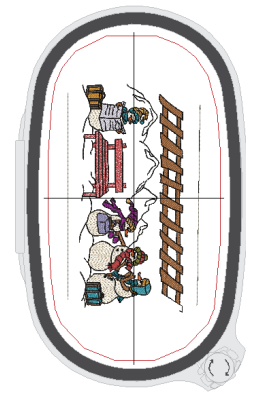

Top of the Fabric



Top of the Fabric

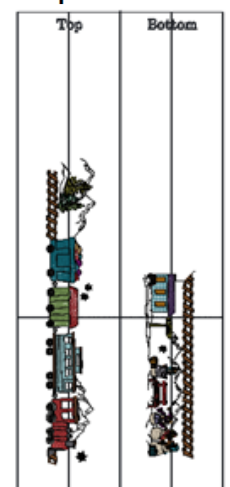



## 4 Borders Folder / #2 Bottom Border / Hooping 3

Attach the hoop and the grid (no fabric) to the module.

### Open #3 Lodge

**Step #1** Advance to the **embroidery sewing screen** to go to the 1<sup>st</sup> stitch of the design.

**Step #2** Lower the needle, lay an arrow shaped post it note on the grid with the tip of the arrow touching the needle. (The arrow is about 3 1/2" BELOW & 2 1/2" to the RIGHT of center on the grid.)

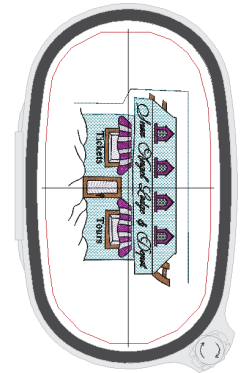

### Fabric Position:

To hoop this design the **Top of the Fabric** is positioned at the **TOP** of the hoop.

See **Example #3** below for **1st stitch** position



Top of the Fabric

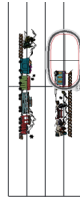

Hoop the fabric with the **arrow on the grid pointing to the green start arrow** see **Example #3**. The drawn lines on the fabric must be parallel and perpendicular to the lines on the grid. **REMOVE** the grid from the hoop and attach the hoop to the module. **Float one piece of heavy weight tear away stabilizer** (sprayed with 505) **under the attached hoop**.

No Thread Color #1 **Placement Line**. The needle is positioned at the green start arrow **see Example #3**. The arrow **on the grid points to the end of the stitched in line**. Sew Color #1 without thread: it sews from the start arrow to the down & left to the end arrow (shown in red) following the outline of the Lodge.

Re-position if needed to follow the line.

Add a basting box, sew it out then turn it off.

Advance to **Color #2**.

Thread Color #2 **Blue (c4010 w3810) # \_\_\_\_\_**

Embroider the basting stitches & Lodge.

Thread Color #3 **Nutmeg (0932) # \_\_\_\_\_**

Embroider the trim on the Lodge.

Thread Color #4 **White (0015) # \_\_\_\_\_**

Embroider the windows and awning stripes.

Thread Color #5 **Purple (c2721 w2723) # \_\_\_\_\_**

Embroider the dormers and awning stripes.

Thread Color #6 **Black (0020) # \_\_\_\_\_**

Embroider the outlining & Words.

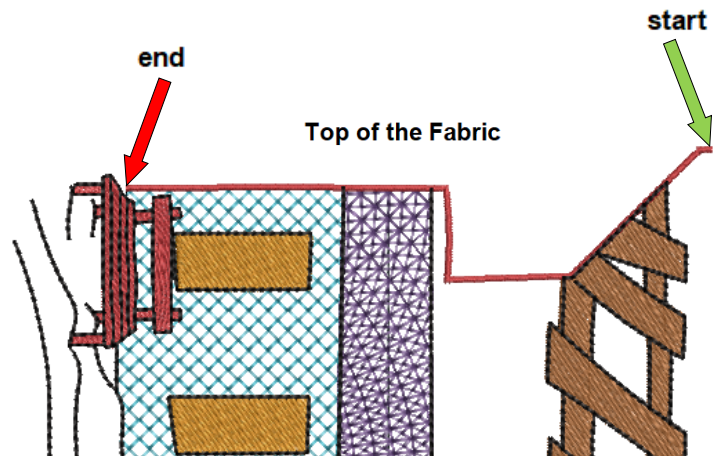

Top of the Fabric

Example #3.

Remove the hoop from the module and the fabric from the hoop.

Gently remove the stabilizer from the back.



Remove all the basting stitches.

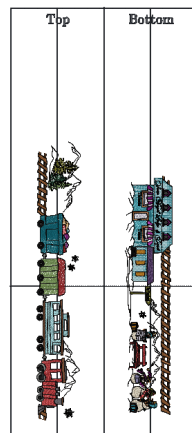

## 4 Borders Folder / #2 Bottom Border / Hooping 4

Attach the hoop and the grid (no fabric) to the module.

### Open #4 Benches

**Step #1** Advance to the **embroidery sewing screen** to go to the 1<sup>st</sup> stitch of the design.

**Step #2** Lower the needle, lay an arrow shaped post it note on the grid with the tip of the arrow touching the needle. (The arrow is positioned about 4 1/4" BELOW & 1 1/2" to the RIGHT of center on the grid.)

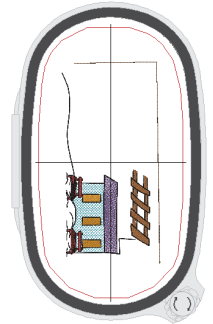

### Fabric Position:

To hoop this design the **Top of the Fabric** is positioned at the **TOP** of the hoop.

See **Example #3** below for 1<sup>st</sup> stitch position.

Top of the Fabric

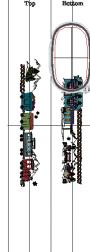

Hoop the fabric with the **arrow on the grid pointing to the green start arrow** see **Example #4**. The drawn lines on the fabric must be parallel and perpendicular to the lines on the grid. **REMOVE** the grid from the hoop and attach the hoop to the module. **Float one piece of heavy weight tear away stabilizer** (sprayed with 505) **under the attached hoop**.

No Thread Color #1 **Placement Line**. The needle is positioned at the green start arrow see **Example #4**. The arrow on the grid points to the **corner front of the roof** (end of black line). Sew Color #1 without thread: it sews from the start arrow to the left to the end arrow (shown in red) following the outline of the Lodge.

Re-position if needed to follow the line.

Add a basting box, sew it out then turn it off. Advance to **Color #2**.

Thread Color #2 **Nutmeg (0932) # \_\_\_\_\_**  
Embroider the basting stitches & railroad track.

Thread Color #3 **Purple (c2702 w2810) # \_\_\_\_\_**  
Embroider the roof of the Lodge..

Thread Color #4 **Blue (c4010 w3810) # \_\_\_\_\_**  
Embroider the Lodge.

Thread Color #5 **Gold (c0824 w0721) # \_\_\_\_\_**  
Embroider the windows.

Thread Color #6 **Red (c1800 w1911) # \_\_\_\_\_**  
Embroider the benches.

Thread Color #7 **Black (0020) # \_\_\_\_\_**  
Embroider the outlining.

Top of the Fabric

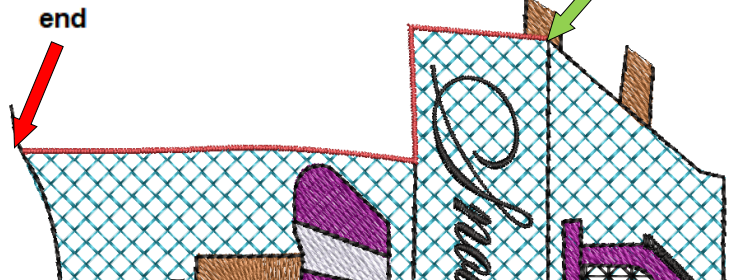

Example #4.

Remove the hoop from the module and the fabric from the hoop.  
Gently remove the stabilizer from the back.

Remove all the basting stitches.

Top of the Fabric

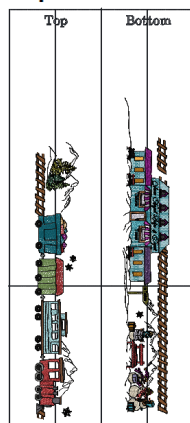

# 4 Borders Folder / #3 Left Border Folder / Hooping 1

Use the prepared and marked fabric for the **Left & Right Borders**

Attach the hoop and the grid (no fabric) to the module.

## Open #1 Car

- Step #1** Advance to the **embroidery sewing screen** to go to the 1<sup>st</sup> stitch of the design.
- Step #2** Lower the needle, lay an arrow shaped post it note on the grid with the tip of the arrow touching the needle. (The arrow is positioned about 1¼" **BELOW** & ¼" **RIGHT** of center on the grid.)

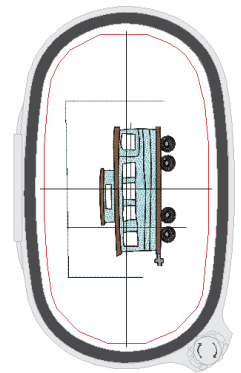

## Fabric Position:

To hoop this design the **Top of the Fabric** is positioned at the **TOP** of the hoop. See **Example #1** below for 1st stitch position.

Top of the Fabric

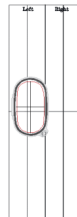

Hoop the fabric with the **arrow on the grid pointing to the green start arrow** see **Example #1**. The drawn lines on the fabric must be parallel and perpendicular to the lines on the grid. **REMOVE** the grid from the hoop and attach the hoop to the module. **Float one piece of heavy weight tear away stabilizer** (sprayed with 505) **under the attached hoop**.

No Thread Color #1 **Placement Line**. The needle is positioned at the green start arrow see **Example #1**. The arrow on the grid points to the **Center Crosshair on the left side of the FABRIC**. Sew Color #1 without thread: it sews from the start arrow upward to the end arrow following the drawn line. Re-position if needed to follow the line. Add a basting box, sew it out then turn it off. Advance to Color #2.

Thread Color #2 **Blue (c4240 w3750) # \_\_\_\_\_**  
Embroider the basting stitches (C shape around car) & train car.

Thread Color #3 **Pony (1233) # \_\_\_\_\_**  
Embroider the wood trim on the train.

Thread Color #4 **Sterling (0142) # \_\_\_\_\_**  
Embroider the center of the wheels & hitch.

Thread Color #5 **Black (0020) # \_\_\_\_\_**  
Embroider the wheels, outlining and the **"Center Placement Line"**.

Remove the hoop from the module and the fabric from the hoop. Gently remove the basting stitches around the car but...

Do NOT remove the **Center Placement Line** Use this Line for centering the Border Strip to quilt top. If the line is accidentally removed please refer to p.83 for position of the Center Placement Line.

Carefully remove the stabilizer from the back without pulling out the **Center Placement Line**.

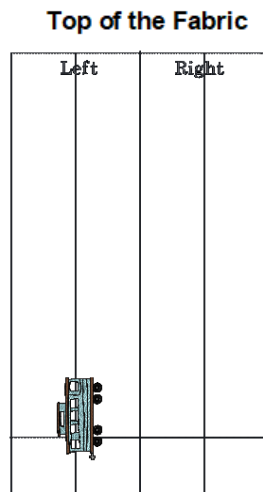
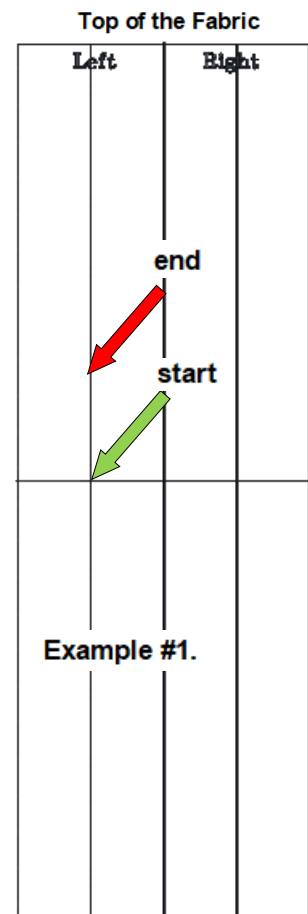

## 4 Borders Folder / #3 Left Border Folder / Hooping 2

Attach the hoop and the grid (no fabric) to the module.

### Open #2 Engine

**Step #1** Advance to the **embroidery sewing screen** to go to the 1<sup>st</sup> stitch of the design.

**Step #2** Lower the needle, lay an arrow shaped post it note on the grid with the tip of the arrow touching the needle. (The arrow is positioned about 4 1/2" BELOW & 1/4" to the LEFT of center on the grid.)

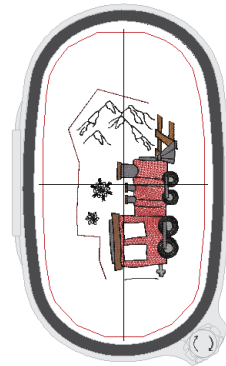

Top of the Fabric



### Fabric Position:



To hoop this design the **Top of the Fabric** is positioned at the **TOP** of the hoop.

See **Example #2 below** for **1st stitch** position.

Hoop the fabric with the **arrow on the grid pointing to the green start arrow** see **Example #2**. The drawn lines on the fabric must be parallel and perpendicular to the lines on the grid. **REMOVE** the grid from the hoop and attach the hoop to the module. **Float one piece of heavy weight tear away stabilizer** (sprayed with 505) **under the attached hoop**.

No Thread Color #1 **Placement Line**. The needle is positioned at the green start arrow see **Example #2**. The arrow on the grid points to the **green arrow in Example #2**. **See green arrow**. Sew Color #1 without thread: it sews from the start arrow (on the intersection of the black outline) right to the end arrow following the black outline of the train car. (Shown in red)  
 Re-position if needed to follow the line.  
 Add a basting box, sew it out then turn it off. Advance to Color #2.

Thread Color #2 **Red (c1800 w1911) # \_\_\_\_\_**  
 Embroider the basting stitches & train car.

Thread Color #3 **Leadville (0112) # \_\_\_\_\_**  
 Embroider the steel parts, cow catcher, & smoke stack.

Thread Color #4 **Nutmeg (0932) # \_\_\_\_\_**  
 Embroider the tracks.

Thread Color #5 **Sterling (0142) # \_\_\_\_\_**  
 Embroider the center of the wheels & hitch.

Thread Color #6 **Pony (1233) # \_\_\_\_\_**  
 Embroider the wood trim on the train.

Thread Color #7 **Black (0020) # \_\_\_\_\_**  
 Embroider the wheels and outlining.

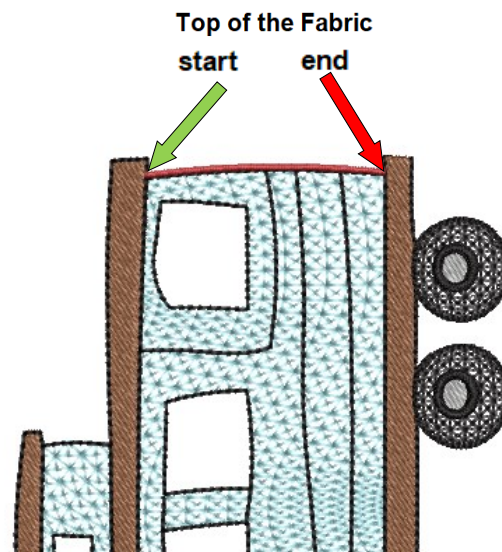

Example #2.

Remove the hoop from the module and the fabric from the hoop.

Gently remove the all basting stitches around the engine and remove the stabilizer.

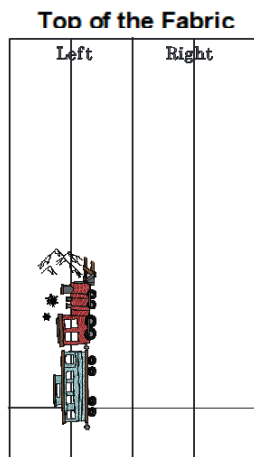



## 4 Borders Folder / #3 Left Border Folder / Hooping 3

Attach the hoop and the grid (no fabric) to the module.

### Open #3 Pump Trolley

**Step #1** Advance to the **embroidery sewing screen** to go to the 1<sup>st</sup> stitch of the design.

**Step #2** Lower the needle, lay an arrow shaped post it note on the grid with the tip of the arrow touching the needle. (The arrow is positioned about 5" ABOVE & 1/2" to the LEFT of center on the grid.)

### Fabric Position:

To hoop this design the **Top of the Fabric** is positioned at the **TOP** of the hoop.

See **Example #3** below for **1st stitch** position

Top of the Fabric

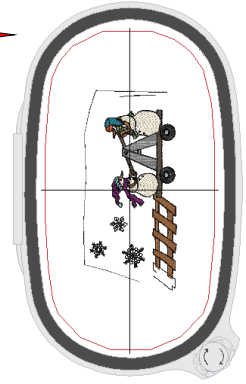

Hoop the fabric with the **arrow on the grid pointing to the green start arrow** see **Example #3**. The drawn lines on the fabric must be parallel and perpendicular to the lines on the grid. **REMOVE** the grid from the hoop and attach the hoop to the module. **Float one piece of heavy weight tear away stabilizer** (sprayed with 505) **under the attached hoop**.

No Thread Color #1 **Placement Line**. The needle is positioned at the green start arrow see **Example #3**. The arrow on the grid points to the **green arrow in Example #3**. **See green arrow**. Sew Color #1 without thread: it sews from the start arrow right to the end arrow following the edge of the train car. (Shown in red)  
Re-position if needed to follow the line.  
Add a basting box, sew it out then turn it off. Advance to Color #2.

Thread Color #2 **Muslin (0870) # \_\_\_\_\_**  
Embroider the basting stitches & snowmen.

Thread Color #3 **Blue (c4116 w3902) # \_\_\_\_\_**  
Embroider the hat.

Thread Color #4 **Purple (c2721 w2723) # \_\_\_\_\_**  
Embroider the scarf.

Thread Color #5 **Nutmeg (0932) # \_\_\_\_\_**  
Embroider the tracks and arms.

Thread Color #6 **Sterling (0142) # \_\_\_\_\_**  
Embroider the frame & center of wheels.

Thread Color #7 **Chocolate (1876) # \_\_\_\_\_**  
Embroider the hand pumper base & handle.

Thread Color #8 **Green (c5610 w0453) # \_\_\_\_\_**  
Embroider the scarf.

Thread Color #9 **Blue (c4240 w3750) # \_\_\_\_\_**  
Embroider the knit hat trim.

Thread Color #10 **Orange (c1304 w1335) # \_\_\_\_\_**  
Embroider the noses & hat trim.

Thread Color #11 **Black (0020) # \_\_\_\_\_**  
Embroider the **Placement Line** for the next Hooping, the wheels and outlining.

Remove the hoop from the module and the fabric from the hoop.

Gently remove the stabilizer from the back.

Remove all the basting stitches.

Top of the Fabric

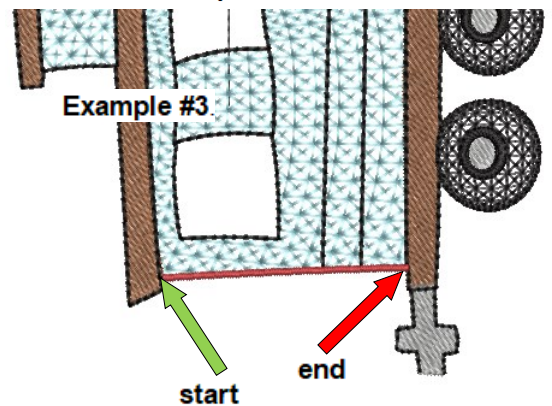

Top of the Fabric

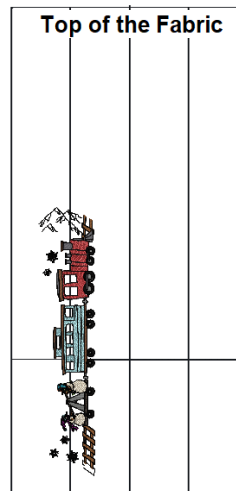

## 4 Borders Folder / #3 Left Border Folder / Hooping 4

Attach the hoop and the grid (no fabric) to the module.

### Open #4 Mountains

**Step #1** Advance to the **embroidery sewing screen** to go to the 1<sup>st</sup> stitch of the design.

**Step #2** Lower the needle, lay an arrow shaped post it note on the grid with the tip of the arrow touching the needle. (The arrow is about 2 1/2" ABOVE & 2" to the RIGHT of center on the grid.)

### Fabric Position:

To hoop this design the **Top of the Fabric is positioned at the TOP** of the hoop.

See **Example #4** below for 1st stitch position

Top of the Fabric

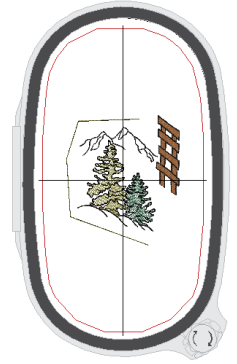
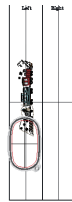

Hoop the fabric with the **arrow on the grid pointing to the green start arrow** see **Example #4**. The drawn lines on the fabric must be parallel and perpendicular to the lines on the grid. **REMOVE** the grid from the hoop and attach the hoop to the module. **Float one piece of heavy weight tear away stabilizer** (sprayed with 505) **under the attached hoop**.

No Thread Color #1 **Placement Line**. The needle is positioned at the green start arrow see **Example #4**. The arrow on the grid points to the **green arrow in Example #4**. See **green arrow**. Sew Color #1 without thread: it sews from the start arrow up & to the right to the end arrow following the edge of the train track.

(Placement Line shown in red)

Re-position if needed to follow the line.

Add a basting box, sew it out then turn it off.

Advance to Color #2.

Thread Color #2 **Yellowgreen (6043) # \_\_\_\_\_**  
Embroider the basting stitches & left tree.

Thread Color #3 **Nutmeg (0932) # \_\_\_\_\_**  
Embroider the tracks.

Thread Color #4 **Green (c5324 w5934) # \_\_\_\_\_**  
Embroider the right tree.

Thread Color #5 **Black (0020) # \_\_\_\_\_**  
Embroider the outlining & mountains.

Top of the Fabric

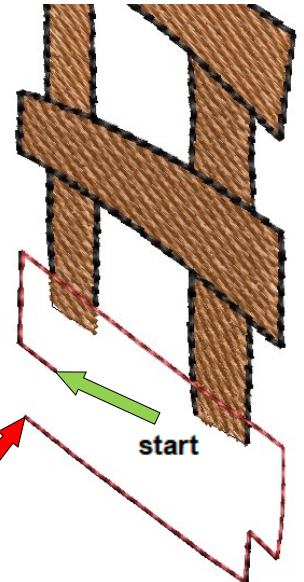
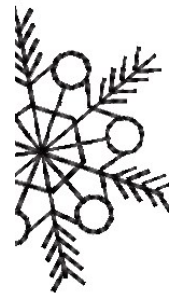

Remove the hoop from the module and the fabric from the hoop.  
Gently remove the stabilizer from the back.

Remove all the basting stitches.

Top of the Fabric

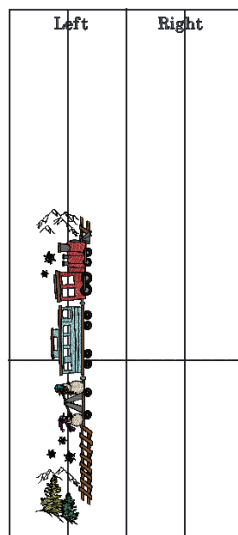

# 4 Borders Folder / #4 Right Border / Hooping 1

Attach the hoop and the grid (no fabric) to the module.

## Open #1 Cars

**Step #1** Advance to the **embroidery sewing screen** to go to the 1<sup>st</sup> stitch of the design.

**Step #2** Lower the needle, lay an arrow shaped post it note on the grid with the tip of the arrow touching the needle. (The arrow is positioned about 1/2" ABOVE & 1/2" to the RIGHT of center on the grid.)

## Fabric Position:

To hoop this design the **Top of the Fabric** is positioned at the **TOP** of the hoop. See **Example #1** below for **1st stitch** position.

Top of the Fabric

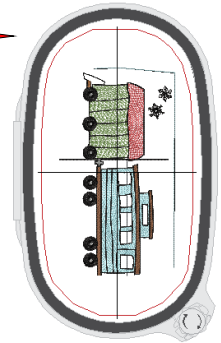

Hoop the fabric with the **arrow on the grid pointing to the green start arrow** see **Example #1**. The drawn lines on the fabric must be parallel and perpendicular to the lines on the grid. **REMOVE** the grid from the hoop and attach the hoop to the module. **Float one piece of heavy weight tear away stabilizer** (sprayed with 505) **under the attached hoop**.

No Thread Color #1 **Placement Line**. The needle is positioned at the green start arrow see **Example #1**. The arrow on the grid points to the **Center Crosshair on the Right**. See **green start arrow**. Sew Color #1 without thread: it sews from the start arrow downward to the end arrow following the drawn line.

Re-position if needed to follow the line.

Add a basting box, sew it out then turn it off. Advance to **Color #2**.

Thread Color #2 **Blue (c4240 w3750) # \_\_\_\_\_**  
Embroider the basting stitches & passenger car.

Thread Color #3 **Red (c1800 w1911) # \_\_\_\_\_**  
Embroider the roof of the box car.

Thread Color #4 **Green (c5610 w0453) # \_\_\_\_\_**  
Embroider the box car.

Thread Color #5 **Pony (1233) # \_\_\_\_\_**  
Embroider the wood trim on passenger car.

Thread Color #6 **Sterling (0142) # \_\_\_\_\_**  
Embroider the center of the wheels & hitch.

Thread Color #7 **Nutmeg (0932) # \_\_\_\_\_**  
Embroider the track.

Thread Color #8 **Black (0020) # \_\_\_\_\_**  
Embroider the outlining & **Center Placement Line**.

Remove the hoop from the module and the fabric from the hoop.

Gently remove the stabilizer from the back.

Remove the basting stitches...but

**Do NOT** remove the **Center Placement Line**  
Use this Line for centering the Border Strip to quilt top.  
If the line is accidentally removed please refer to p.83 for position of the Center Placement Line.

Top of the Fabric

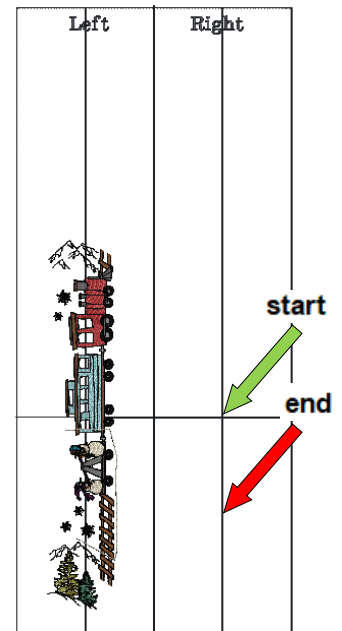

Example #1.

Top of the Fabric

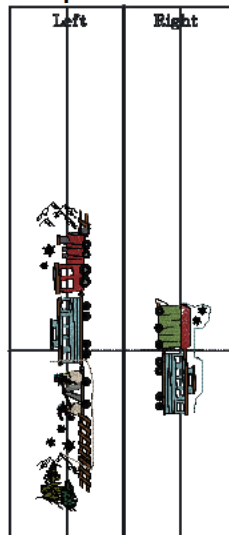

## 4 Borders Folder / #4 Right Border / Hooping 2

Attach the hoop and the grid (no fabric) to the module.

### Open #2 Engine

**Step #1** Advance to the **embroidery sewing screen** to go to the 1<sup>st</sup> stitch of the design.

**Step #2** Lower the needle, lay an arrow shaped post it note on the grid with the tip of the arrow touching the needle. (The arrow is positioned about 5½" ABOVE & ¼" to the RIGHT of center on the grid.)

Top of the Fabric

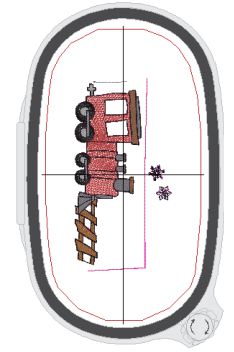

### Fabric Position:

To hoop this design the **Top of the Fabric** is positioned at the **TOP** of the hoop.

This design embroiders below the last design.

See **Example #2 below** for **1st stitch** position.

Hoop the fabric with the **arrow on the grid pointing to the green start arrow** see **Example #2**. The drawn lines on the fabric must be parallel and perpendicular to the lines on the grid. **REMOVE** the grid from the hoop and attach the hoop to the module. **Float one piece of heavy weight tear away stabilizer** (sprayed with 505) **under the attached hoop**.

No Thread Color #1 **Placement Line**. The needle is positioned at the green start arrow see **Example #2**. The arrow on the grid points to the **intersection between the car and roof trim**. Sew Color #1 without thread: it sews from the start arrow to the left to the end arrow following the outline of the car. Re-position if needed to follow the line. Add a basting box, sew it out then turn it off. Advance to **Color #2**.

Thread Color #2 **Red (c1800 w1911) # \_\_\_\_\_**

Embroider the basting stitches and engine.

Thread Color #3 **Leadville (0112) # \_\_\_\_\_**

Embroider the steel parts, cow catcher, & smoke stack.

Thread Color #4 **Nutmeg (0932) # \_\_\_\_\_**

Embroider the tracks.

Thread Color #5 **Sterling (0142) # \_\_\_\_\_**

Embroider the center of the wheels.

Thread Color #6 **Pony (1233) # \_\_\_\_\_**

Embroider the trim on the engine.

Thread Color #7 **Black (0020) # \_\_\_\_\_**

Embroider the outlining.

Top of the Fabric

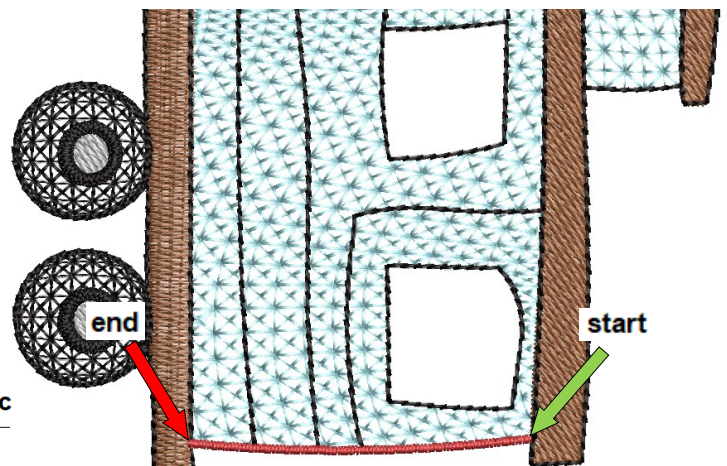

Example #2.

Top of the Fabric

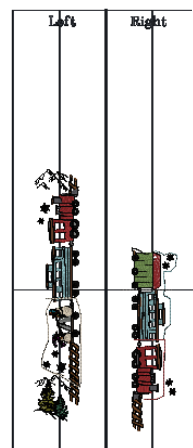

Remove the hoop from the module and the fabric from the hoop.

Gently remove the stabilizer from the back.



## 4 Borders Folder / #4 Right Border / Hooping 3

Attach the hoop and the grid (no fabric) to the module.

### Open #3 Skier

**Step #1** Advance to the **embroidery sewing screen** to go to the 1<sup>st</sup> stitch of the design.

**Step #2** Lower the needle, lay an arrow shaped post it note on the grid with the tip of the arrow touching the needle. (The arrow is positioned about 4 1/2" BELOW & 2 1/2" to the LEFT of center on the grid.)

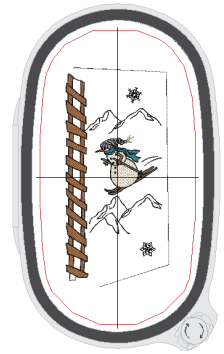

### Fabric Position:

To hoop this design the **Top of the Fabric** is positioned at the **TOP** of the hoop.

This hooping is above the 1st hooping.

See **Example #3** below for **1st stitch** position.



Top of the Fabric

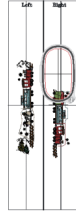

Hoop the fabric with the **arrow on the grid pointing to the green start arrow** see **Example #3**. The drawn lines on the fabric must be parallel and perpendicular to the lines on the grid. **REMOVE** the grid from the hoop and attach the hoop to the module. **Float one piece of heavy weight tear away stabilizer** (sprayed with 505) **under the attached hoop**.

No Thread Color #1 **Placement Line**. The needle is positioned at the green start arrow see **Example #3**. The arrow on the grid points to the **upper left corner of the black outline**. Sew Color #1 without thread: it sews from the start arrow downward following the black outline almost back to the start arrow. Re-position if needed.

Add a basting box, sew it out then turn it off.

Advance to **Color #2**.

Thread Color #2 **Muslin (0870) # \_\_\_\_\_**  
Embroider the basting stitches and skier.

Thread Color #3 **Blue (c4116 w3902) # \_\_\_\_\_**  
Embroider the scarf.

Thread Color #4 **Dawn of Violet (3130) # \_\_\_\_\_**  
Embroider the stripes on the hat.

Thread Color #5 **Pony (1233) # \_\_\_\_\_**  
Embroider the skies.

Thread Color #6 **Green (c5610 w0453) # \_\_\_\_\_**  
Embroider the stripes on the hat.

Thread Color #7 **Sterling (0142) # \_\_\_\_\_**  
Embroider the ski poles.

Thread Color #8 **Nutmeg (0932) # \_\_\_\_\_**  
Embroider the tracks and arms.

Thread Color #9 **Orange (c1304 w1335) # \_\_\_\_\_**  
Embroider the nose.

Thread Color #10 **Black (0020) # \_\_\_\_\_**  
Embroider the outlining & mountains.

start

end

Top of the Fabric

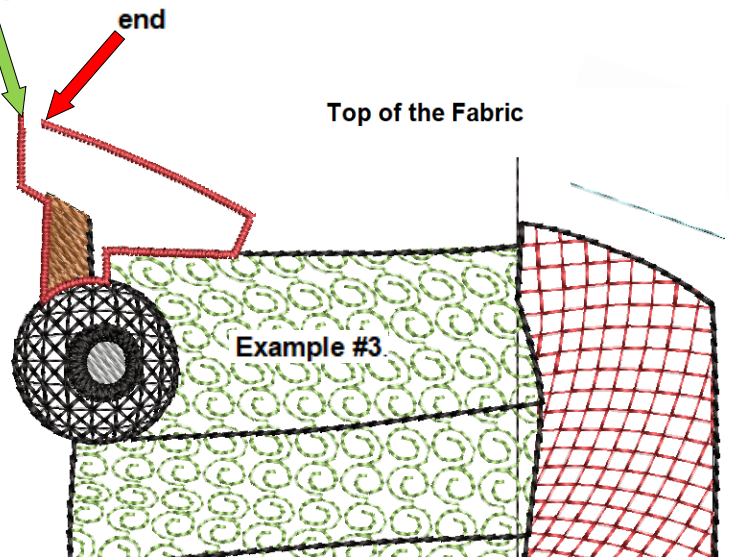

Example #3

Top of the Fabric

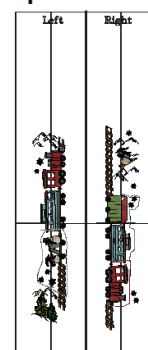

Remove the hoop from the module and the fabric from the hoop.

Gently remove the stabilizer from the back.

Remove all the basting stitches.



Overview of upcoming sections...

**Layout of Blocks** page 75

**Trimming the Embroidered Blocks** page 76

**Cutting the Sashing** page 76

**Piecing the Center Quilt Top** page 76

**Layout of Center Section** page 77

**Embroider Words** page 78-81

**Embroidered Borders** page 82-83

**Sewing on the Embroidered Borders** page 84

**Embroidering the Corners** page 85-92

**Trimming Embroidered Borders** page 93

(Note: trim one side of border only)

**Outer Borders** page 94

# Layout of Blocks

### Top Row:

Tree Trimming or Sledding:

Top Row Left Side

Snow Angels or Smores:

Top Row Right Side

### Middle Row:

Sleigh Ride with Mailbox:

Center Row

Sleigh Ride with Geese:

Center Row

### Bottom Row:

Carolers or Making Friends:

Bottom Row Left Side

Gathering Presents or Ice Skating:

Bottom Row Right Side

The "Snow Country Express" wording is shown below, but you have not actually embroidered it yet!!

33½" Square



33½" Square



## Trimming the Embroidered Blocks

### Top Row:

**Tree Trimming & Sledding:** Cut Block: 16.5" x 8.5" finished size 16" x 8"  
**Snow Angel Block & Smores :** Cut Block: 13" x 8.5" finished size 12.5" x 8"

### Middle Row:

**Sleigh Ride Center Block:** Cut Block: 30.5" x 9.5" finished size 30" x 9" (Remove the basting stitches)

**Hint:** Make sure the vertical & horizontal lines on the ruler are parallel & perpendicular with the lines on the barn and the roof of the barn. This will help you square the block for cutting.

### Bottom Row:

**Carolers & Making Friends:** Cut: 13" x 9.5" finished size 12.5" x 9"  
**Gathering Presents & Ice Skating:** Cut: 16.5 x 9.5 finished size 16" x 9"

**Be accurate!!**

## Cutting the Sashing

Before cutting the fabric, **back the fabric** with **Shape Flex 101** interfacing by Pellon. This will give the Sashing the same weight and texture as the rest of the Quilt top.

**Sashing Fabric:**( $\frac{1}{2}$  yard)

Cut (6) 2" Strips by Width of Fabric 44"+/-

Sub Cut (1) 2" Strip into:

- (1) 2" x 8 $\frac{1}{2}$ " Strip for **Top Row** Sashing
- (1) 2" x 9 $\frac{1}{2}$ " Strip for **Bottom Row** Sashing

Cut (1) 3" Strip by Width of Fabric 44"+/-

(3" Strip is the Sashing below the Center Block: this strip will have the words)

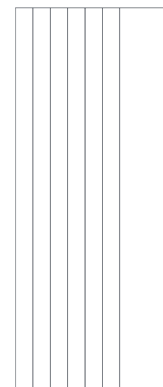

## Piecing the Center

Use scant quarter inch seams. Follow the diagram for placement.

Measure each individual border after you sew the sashing & blocks together.

1. Piece the Top Row: **Measures 30 $\frac{1}{2}$ " wide x 8 $\frac{1}{2}$ " high.**
2. Piece the Center Row: **Measures 30 $\frac{1}{2}$ " wide x 13 $\frac{1}{2}$ " high.**

The **Center section** must be **13 $\frac{1}{2}$ " high**. If it is not, **trim the raw edge of the wider sashing** so the section height measures **13 $\frac{1}{2}$ " high**.

3. Piece the Bottom Row: **Measures 30 $\frac{1}{2}$ " wide x 9 $\frac{1}{2}$ " high.**
4. Sew the Left & Right Side sashings to the Center.  
Must measure **33 $\frac{1}{2}$ " wide x 30 $\frac{1}{2}$ " high**.  
Measure across the top, center & bottom of the Quilt Top to make sure measurements are the same.
5. Sew the Top & Bottom sashings to the Center.  
Must measure **33 $\frac{1}{2}$ " square**. Measure across the Quilt top, center & bottom vertically & horizontally to make sure it is square. If it is not, you need to adjust the seams to get it square.

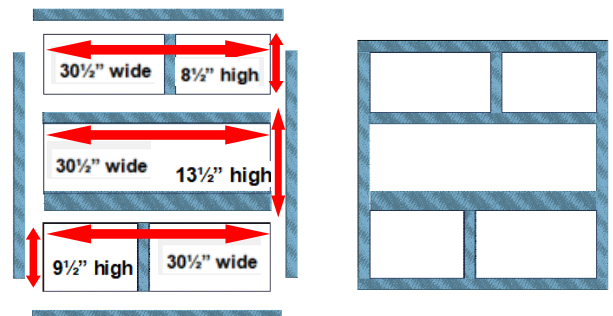

(See next page for Layout)

**This is the only way the railroad corners will fit!!**



## Layout of Center Section (after sewing them together)

### Outer Sashing:

The Outer Sashing 1.75" (1 3/4") has one unfinished edge.

When it is sewn to all 4 of the Embroidered Borders, the sashing will finish at 1.5" (1 1/2) wide.

### Inner Sashing:

The Inner Sashing's finish at 1.5" (1 1/2) wide.

### The Center Sashing:

The Center Sashing finishes at 2.5" (2 1/2") wide.

When assembled, mark the **Center** of all (4) Outer Sashing Strips (16 3/4" from the edge to edge).

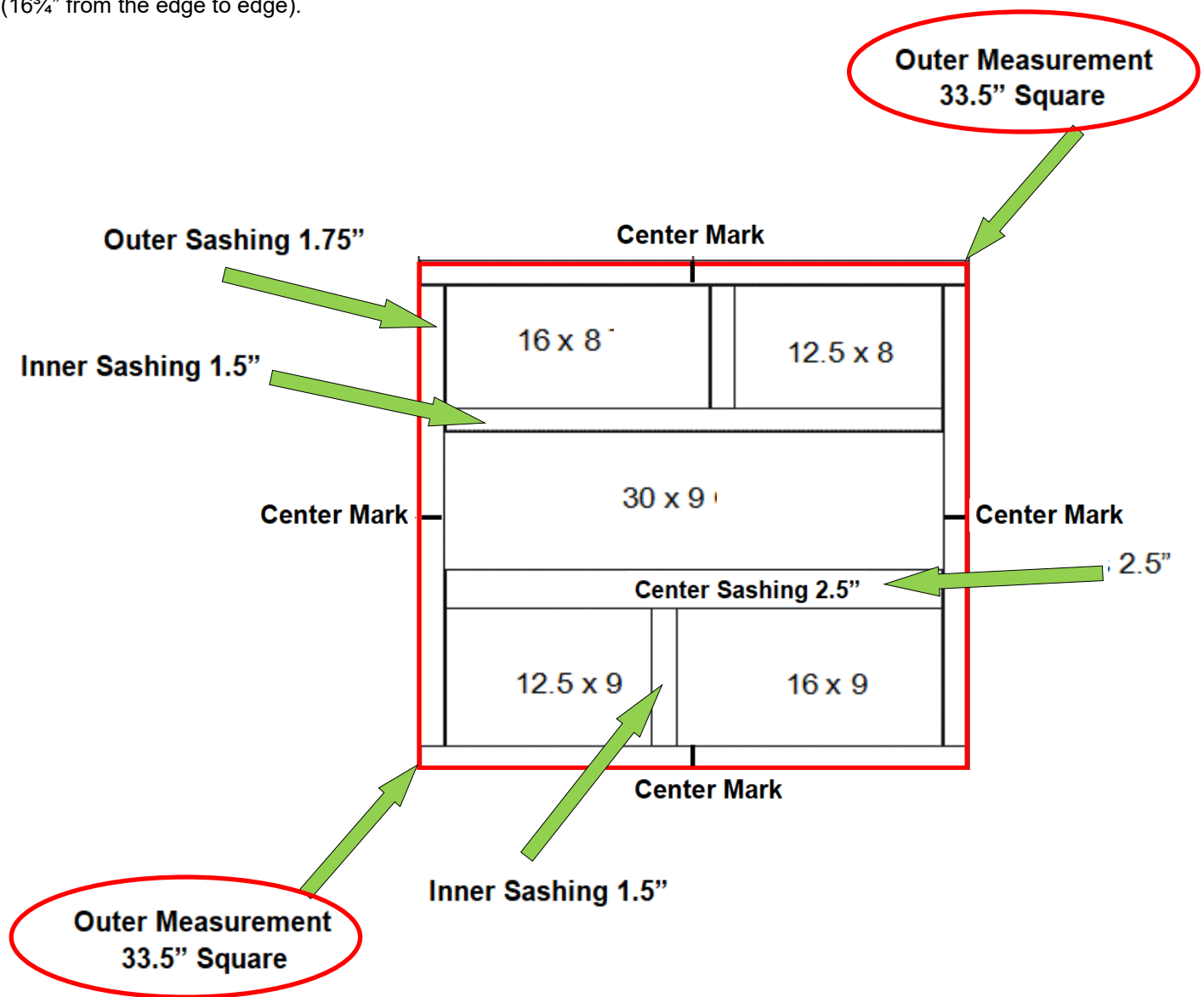

# 5 Words Folder



SNOW COUNTRY EXPRESS

## 5 Words Folder

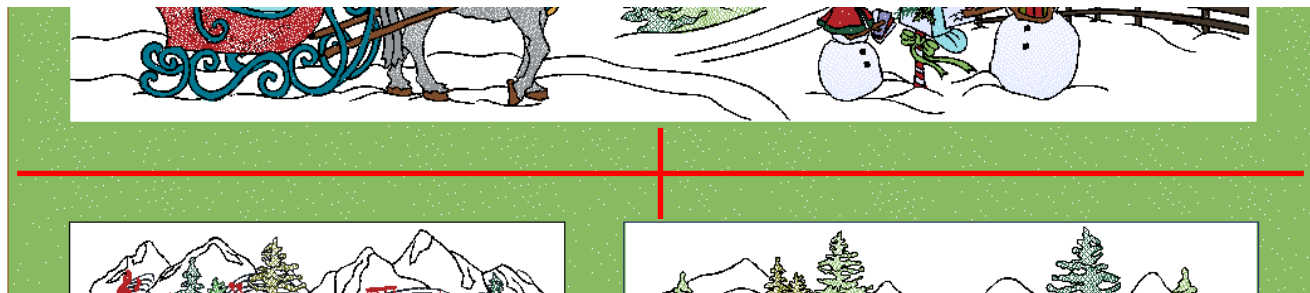

## Fabric Preparation for Words

### Mark the Fabric:

Mark a Center Crosshair on the 2 ½" wide Border.  
This is the Sashing strip under the Sleigh Ride Block.

Make sure it is the full width and height of the Border.  
Definitely make sure the lines you draw are **parallel and perpendicular** to your seams lines.

This will make the words parallel to the seams lines and look perfectly straight.  
See the red Crosshair above in the picture.

### Bobbin Thread:

Fill a bobbin with the same color thread you plan to use for the Words.  
This will ensure that the lettering will look great!

# 5 Words Folder / Hooping 1

Attach the hoop and the grid (no fabric) to the module.

### Open #1 Snow Coun

**Step #1** Advance to the **embroidery sewing screen** to go to the 1<sup>st</sup> stitch of the design.

**Step #2** Lower the needle, lay an arrow shaped post it note on the grid with the tip of the arrow touching the needle. (The arrow is positioned about 4½" BELOW center the grid).

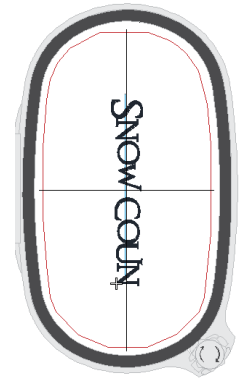

### Fabric Position:



To hoop this design the

### Top of the Fabric

is **rotated to the RIGHT** of the hoop.

See **Example #1** below for **1st stitch** position.



Top of the Fabric

Hoop the fabric with the **arrow on the grid pointing to the**

**Center Crosshair on the FABRIC.** See **Example #1.**

The drawn lines on the fabric must be parallel and perpendicular to the seam lines.

Remove the grid from the hoop and attach the hoop to the module.

**Float 2 heavy weight tear away stabilizers** (sprayed with 505) **under the attached hoop, MANDATORY!**

**TIP: Match the Bobbin thread color to the top thread color!**

No Thread, Color #1 **Placement Line.** The needle is positioned over the

**Center Crosshair on the FABRIC.** See green start arrow in

**Example #1.** Sew Color #1 without thread. It sews from the

start arrow upward following the drawn line, to the end arrow.

Reposition if needed to follow the line.

Add a basting box then turn it off.

Advance to **Color #2.**

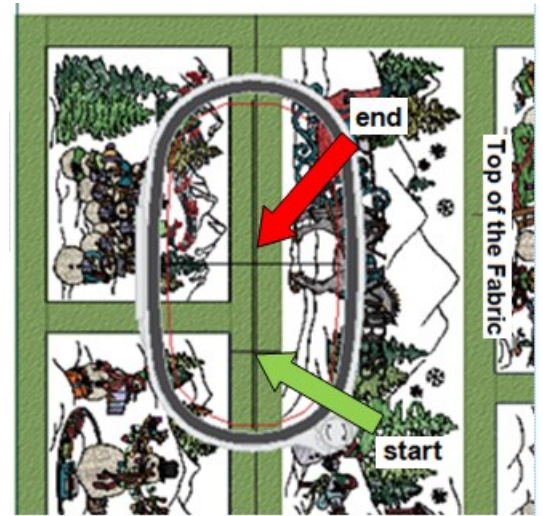

**Example #1.**

Thread Color #2 **Whatever Color you desire # \_\_\_\_\_**

Make sure the thread color is a high contrast to your fabric color.

Embroider the words. Some stems on certain letters **sew over themselves twice (like the N).**

Remove the hoop from the module and the fabric from the hoop. Gently remove the stabilizer from the back.



Remove all the basting stitches.

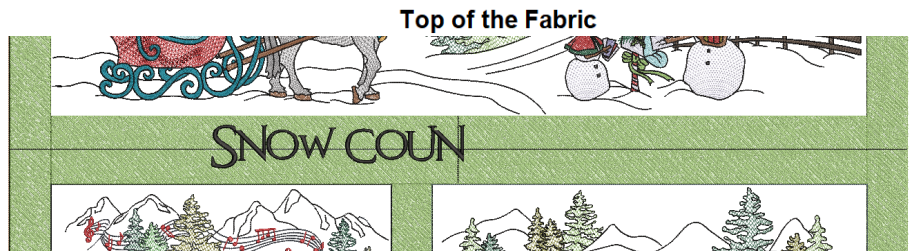

Top of the Fabric



## 5 Words Folder / Hooping 2



Attach the hoop and the grid (no fabric) to the module.

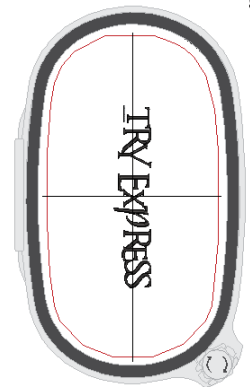

### Open #2 try Express

**Step #1** Advance to the **embroidery sewing screen** to go to the 1<sup>st</sup> stitch of the design.

**Step #2** Lower the needle, lay an arrow shaped post it note on the grid with the tip of the arrow touching the needle. (The arrow is positioned about 4½" ABOVE center the grid).



### Fabric Position:

To hoop this design the

### Top of the Fabric

is rotated to the **RIGHT** of the hoop.

See **Example #2** below for 1st stitch position.



### Example #2.

Hoop the fabric with the **arrow on the grid pointing to the bottom of the "N"**. See **Example #2**. The drawn lines on the fabric must be parallel and perpendicular to the seam lines. Remove the grid from the hoop and attach the hoop to the module.

**Float tear away stabilizer** (sprayed with 505) **under the attached hoop, MANDATORY!**

### No Thread, Color #1 Needle Alignment.

The needle is positioned at the bottom tip of the "N" in the word "Coun" from the last hooping.

See green start arrow in **Example #2**.

Do Not sew Color #1.

Add a basting box then turn it off. Advance to **Color #2**.

Thread Color #2 **Same Color as Hooping 1 #** \_\_\_\_\_

Embroider the words.

**The "T" in country will embroider over the top part of the "N", don't worry, it's supposed to!**

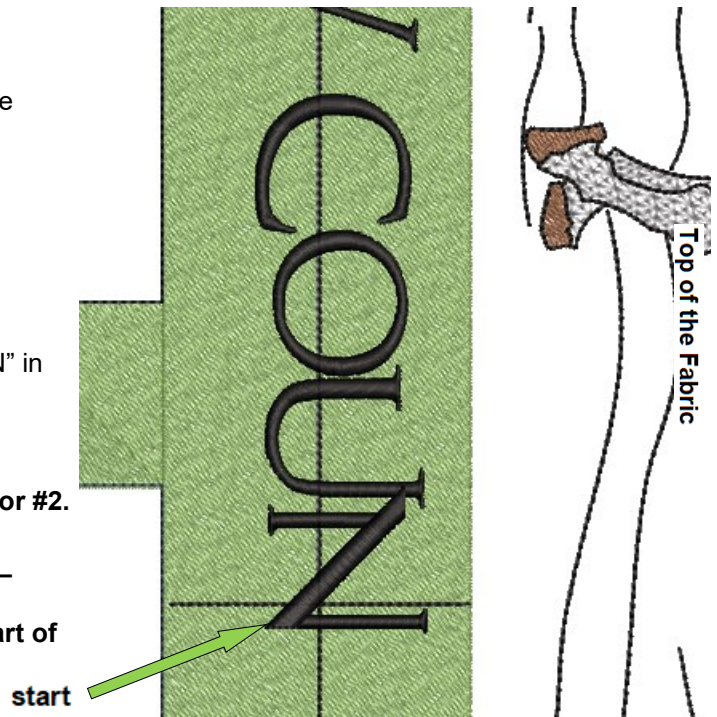

Remove the hoop from the module and the fabric from the hoop. Gently remove the stabilizer from the back. Remove all the basting stitches.



## Embroidered Borders



**Please read this page before cutting!**

- Separate the borders by cutting on the **Center drawn line**. See red dotted line
- Now you have 4 separate borders.

Remove all the marking from the embroidered borders.

(i.e. water soluble marks, iron off pens, removable pens)

When the marking are removed **press** with **spray starch** and iron flat.

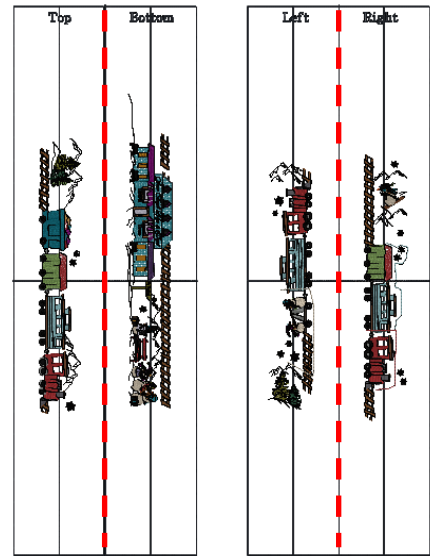
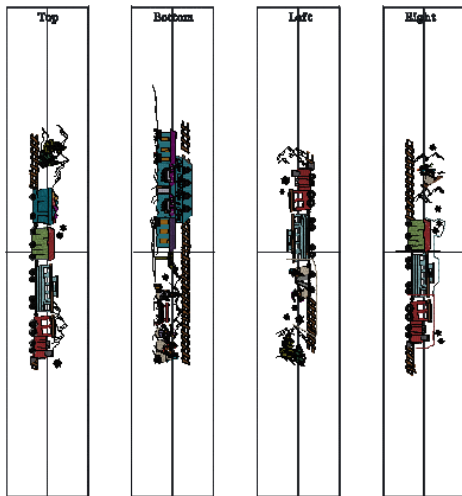

Drawn Line  
& Cut Line

- Draw a straight line on the **INNER EDGE** side, 1" below the train track & wheels.
- The Inner Edge has the train track closest to the edge. See **Drawn Line** green arrow.
- Place two or more straight edge rulers together (short ends) to get at least 48". (i.e. 6"x24") This will give you a perfectly straight line to work with. Extend the line the full length of the border strip. The bottom of the wheels & the bottom most part of the track should form a straight line.

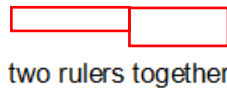

two rulers together

- Draw the **Outer Edge** line 6 1/2" opposite of the **Inner Edge** line. The drawn line is the full length of the border strip. The **length** of the border strips have not been cut yet.
- Cut "**only**" the long **INNER EDGE** side on each border strip. See the red dotted line in the picture. Write **Do Not Cut** on the **Outer Edge** line on the fabric to help you remember not to cut that side of the fabric strip.
- **DO NOT TRIM** the length yet.

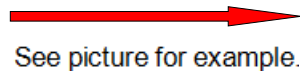

See picture for example.

**Do not remove the Center Placement Stitches**

(see next page if your stitches were accidentally removed)

Drawn Line  
& Cut Line

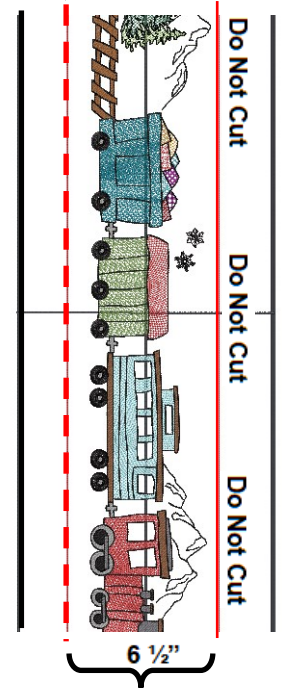
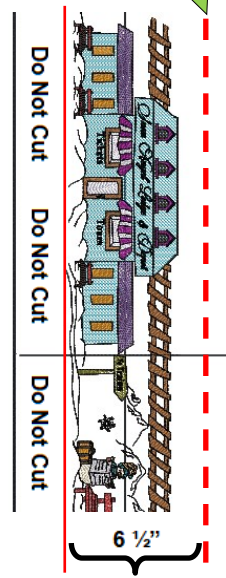



### Embroidered Border Center Placement Lines

If you accidentally removed the stitches for the Center Placement Line, here is a picture of them! Re-mark if needed. These are **crucial, vital, necessary** for accurate placement of the corners!

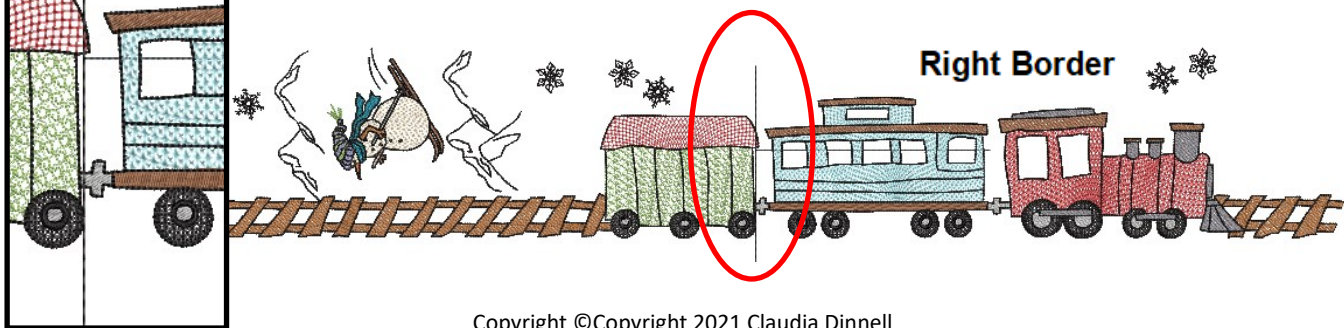
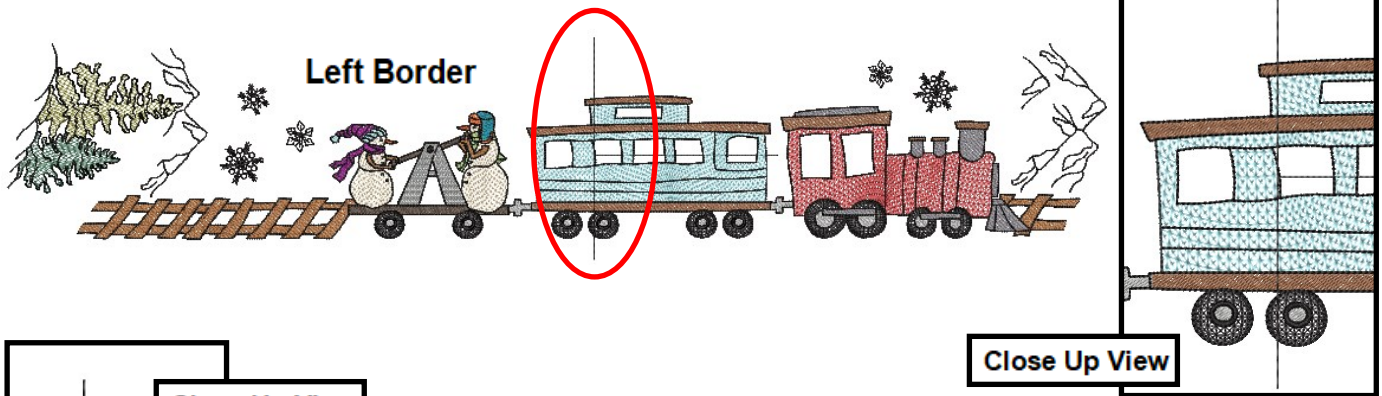

# Sewing on the Embroidered Borders

Use scant quarter inch seams.  
 Always finger press first to **avoid stretching the fabric out of shape**.  
 Press and starch the seams to the Inner Border.

## Side Borders:

1. **Align the centers** of the **Side Embroidered Borders** (use stitched in center line, see LEFT blue arrow) with the **center** of the coordinating **Sashing Side** on the Quilt Top (see RIGHT red arrow).
2. Pin frequently. This method works great because the Terial Magic and Shape Flex keep the fabric from stretching.
3. Sew and press seams toward Sashing.
4. Instead of cutting the Side Borders to the exact length, **DRAW (do not cut) a horizontal line where the cut line would be** (matching the edge of the sashing to the drawn line on the border).
5. Trim both **long ends** of the Embroidered Borders **2" longer** than the **newly drawn line** (this gives you 2" extra fabric if needed to adjust the seams or squaring up in the next step. The exact length will be trimmed later).

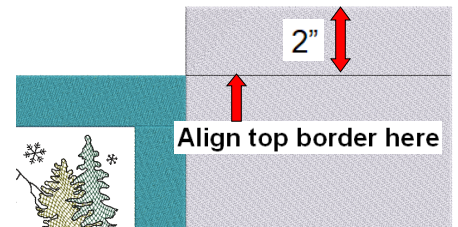
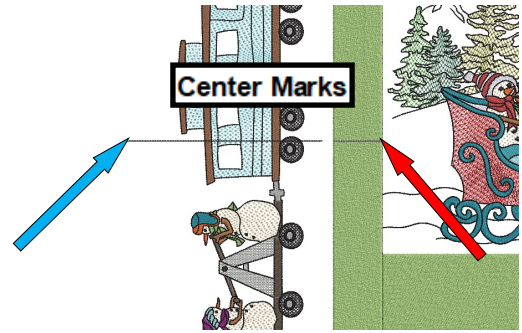

## Top & Bottom Borders

1. Repeat Steps #1, #2 & #3 above. As you pin the edges of the Top & Bottom borders to the quilt top, align the raw edges of the Top & Bottom Borders to match the drawn line of the Side Border. This keeps the borders "square". (See **Align top border here** sign above)
2. Trim the **long length** of the Top & Bottom Borders to the same **width as the quilt top**.

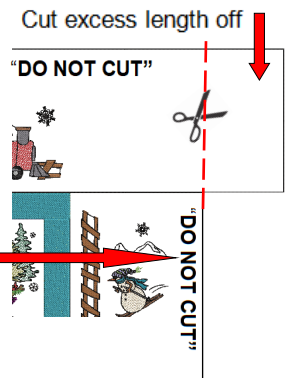

**DO NOT** trim the "DO NOT CUT" marked outer edge width on any of the borders.

## NOTE:

When the all borders are sewn on and pressed flat, place a large square ruler on the corners. (see red box indicating the square ruler in the upper right corner of the quilt). The seam lines should be parallel and perpendicular to the lines on the ruler.

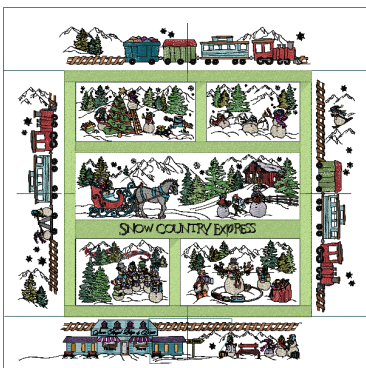

If the lines are not parallel & perpendicular, pick them out and re-sew them. Sometimes the corners like to pull in. This is why pinning frequently helps!

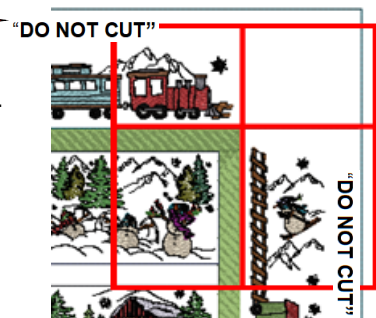

When the seams line up perfectly square with the ruler, trim the extra 2" length off the **Side Borders seam allowance to 1/4"**.

Remove the Stitched in Center Lines  
 Remove the center marks on the Sashing.



# Embroidering the Corners!

## Please Read before embroidering!



### Helpful Hints:

1. **Hooping:** Please make sure you hoop the corners **STRAIGHT**. The **seam lines** on your fabric must be parallel and perpendicular with the grid lines on the template. It is **MORE important** to hoop the corners **straight** than to have the arrow post it note in the exact position. You can always move the design **up/down/left/right** when you get to the machine.  
Do not use any **drawn lines** to hoop the fabric straight, use the **seam lines**.
2. **Orientation:** The fabric must be hooped straight so the incoming design sits **straight/square** in the corner.  
For instance the trees, railroad signal and water tower must be straight/square with the corner to look correct.  
**I do not want you to rotate the design at all** (no pin point or precise positioning) I merely want you to move the design into the correct position by using the **Move Up/Down/Left/Right icon**.
3. **Resizing:** If the design needs to be resized to fit the area, use the **Proportional Sizing icon**.  
If possible, **Unlock** the icon so you will have the ability to alter the **length, & width individually**, not proportionately.

Each of the corner designs can be altered 1%-7% without a problem!!  
i.e. 100% adjusted to 103% wider and/or 100% adjusted to 98% shorter.

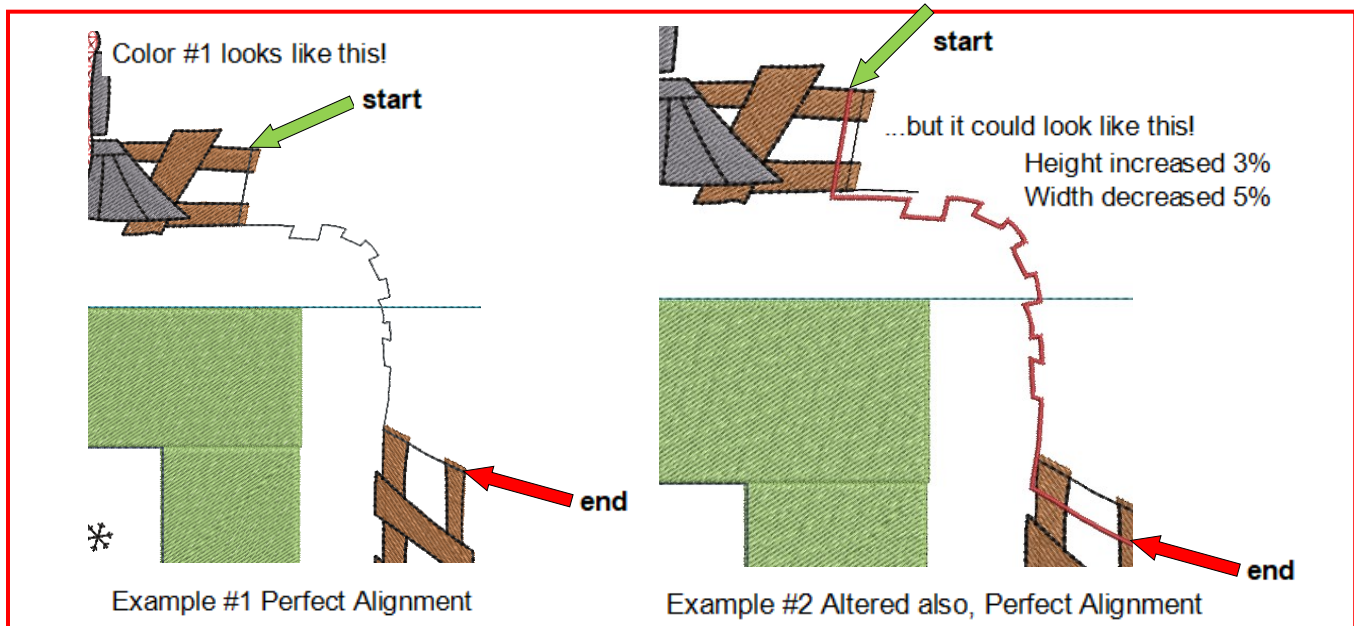

In both examples above, the **start & end arrows** touch the **top outer edge** of the rail.  
It is preferable to align like the instructions see **Example #1**, but it's just fine to adjust the incoming design to fit the area like in **Example #2**.

The first stitch of Color #1 (green start arrow) must touch anywhere on the top outer edge of the rail.  
(get as close as you can to the original alignment)  
The last stitch of Color #1 (red end arrow) must touch anywhere on the top outer edge of the rail.  
(get as close as you can to the original alignment)

## 4 Borders /5 Corners Folder / Hooping 1 Upper Right Track

Attach the hoop and the grid (no fabric) to the module.

### Open #1 Upper Right Track

**Step #1** Advance to the **embroidery sewing screen** to go to the 1<sup>st</sup> stitch of the design.

**Step #2** Lower the needle, lay an arrow shaped post it note on the grid with the tip of the arrow touching the needle. (The arrow is positioned 1 1/2" ABOVE & 1" to the LEFT of center on the grid.)

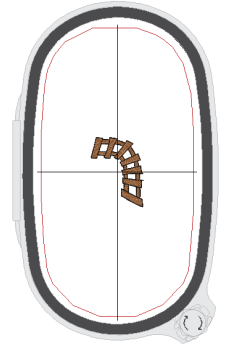

### Fabric Position:



To hoop this design the **Top of the Fabric** is positioned at the **TOP** of the hoop.

See **Example #1** below for 1st stitch position.

Top of the Fabric

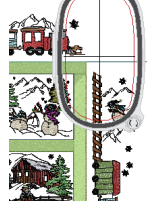

Hoop the fabric with the **arrow on the grid pointing to the green start arrow** see **Example #1**. **REMOVE** the grid from the hoop and attach the hoop to the module. **Float one piece of heavy weight tear away stabilizer** (sprayed with 505) **under the attached hoop**. Make sure to hoop straight with the seams lines, this will ensure a straight fit!!

No Thread Color #1 **Placement Line**. The needle is positioned at the green start arrow see **Example #1**. Sew Color #1 without thread: it sews from the start arrow downward following the outline on the **Top Border** track to the outline on the **Right Border** track. It follows nothing between the two! Re-position if needed to follow the outlines on both tracks (shown in red).

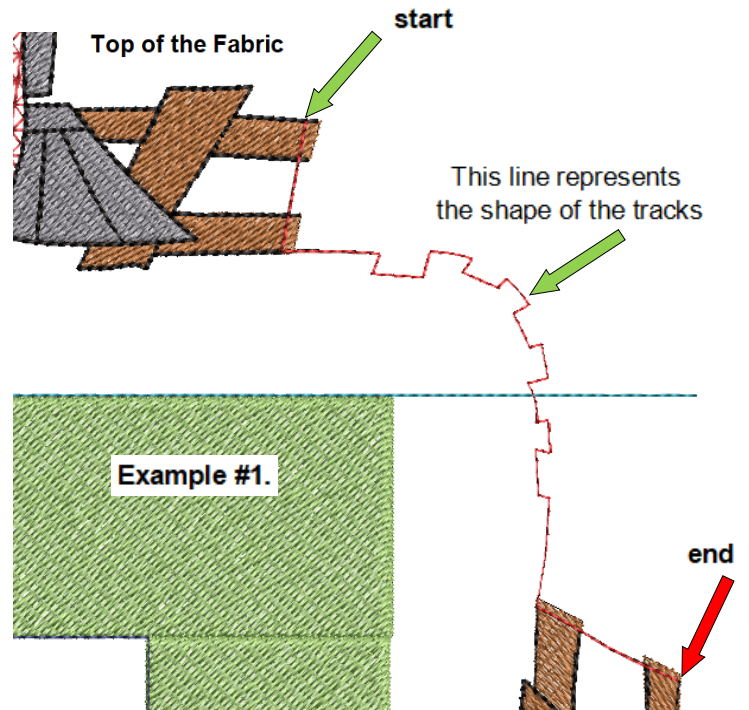

If your measurements do not match mine, you will need to resize the design to make it fit correctly. Use the Resizing Icon and adjust the height & or width.

Add a basting box, sew it out then turn it off. Advance to **Color #2**.

Thread Color #2 **Nutmeg (0932) # \_\_\_\_\_**  
Embroider the tracks.

Thread Color #3 **Black (0020) # \_\_\_\_\_**  
Embroider the outlining.

Remove the hoop from the module and the fabric from the hoop. Gently remove the stabilizer from the back.

Remove all the basting stitches.



## 4 Borders /5 Corners Folder / Hooping 2 Upper Right Trees

Attach the hoop and the grid (no fabric) to the module.

### Open #2 Upper Right Trees

**Step #1** Advance to the **embroidery sewing screen** to go to the 1<sup>st</sup> stitch of the design.

**Step #2** Lower the needle, lay an arrow shaped post it note on the grid with the tip of the arrow touching the needle. (The arrow is positioned 1½” BELOW & 1 ½” to the LEFT of center on the grid.)

### Fabric Position:

To hoop this design the **Top of the Fabric** is positioned at the **TOP** of the hoop.

See **Example #2** below for 1st stitch position

Top of the Fabric

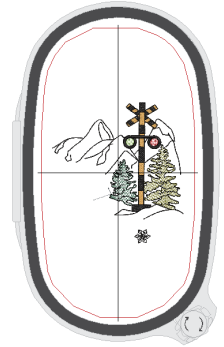

Hoop the fabric with the **arrow on the grid pointing to the green start arrow** see **Example #2**.

**REMOVE** the grid from the hoop and attach the hoop to the module.

The **SEAM** lines on the quilt top must be parallel and perpendicular to the lines on the grid so you hoop straight.

**Float heavy weight tear away stabilizer** (sprayed with 505) **under the attached hoop**.

No Thread Color #1 **Placement Line**. The needle is positioned at the green start arrow see **Example #2**. Sew Color #1 without thread: it sews from the start arrow to the right following the bottom & right side outline on the **5th Rail from the Engine**. If you have resized your design be sure adjust the position to touch as much of the Placement line (shown in red) as possible.

Add a basting box, sew it out then turn it off.

Advance to **Color #2**.

Thread Color #2 **Yellowgreen (6043) # \_\_\_\_\_**  
Embroider the right tree.

Thread Color #3 **Yellow (c0811 w0704) # \_\_\_\_\_**  
Embroider the yellow stripes on the post.

Thread Color #4 **Red (c1800 w 1911) # \_\_\_\_\_**  
Embroider the red light

Thread Color #5 **Green (c5610 w5934) # \_\_\_\_\_**  
Embroider the light.

Thread Color #6 **Green (c5324 w0453) # \_\_\_\_\_**  
Embroider the left tree.

Thread Color #7 **Black (0020) # \_\_\_\_\_**  
Embroider the outlining, railroad post, & mountains.

Remove the hoop from the module and the fabric from the hoop.

Gently remove the stabilizer from the back.

Remove all the basting stitches.

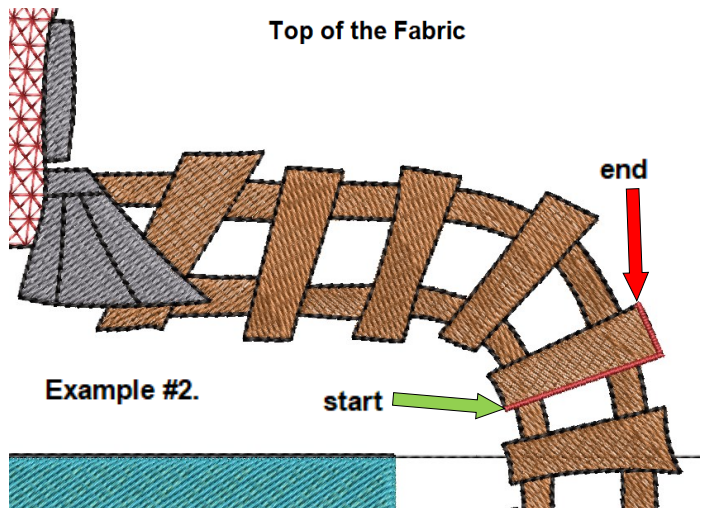



## 4 Borders / 5 Corners Folder / Hooping 3 Upper Left Track

Attach the hoop and the grid (no fabric) to the module.

### Open #3 Upper Left Track

**Step #1** Advance to the **embroidery sewing screen** to go to the 1<sup>st</sup> stitch of the design.

**Step #2** Lower the needle, lay an arrow shaped post it note on the grid with the tip of the arrow touching the needle. (The arrow is positioned about 2½" BELOW & 1" to the LEFT of center on the grid.)

### Fabric Position:

To hoop this design the **Top of the Fabric is Rotated to the BOTTOM** of the hoop.

The fabric is upside down!

See **Example #3** below for **1st stitch** position.

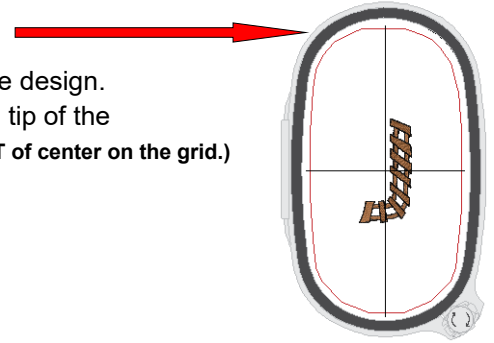
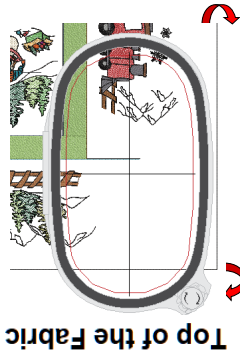

Hoop the fabric with the **arrow on the grid pointing to the green start arrow** see **Example #3**. The drawn lines on the fabric must be parallel and perpendicular to the lines on the grid. **REMOVE** the grid from the hoop and attach the hoop to the module. **Float one piece of heavy weight tear away stabilizer** (sprayed with 505) **under the attached hoop**.

No Thread Color #1 **Placement Line**. The needle is positioned at the green start arrow see **Example #3**. The arrow on the grid points to the **lower left corner of the black outline**. Sew Color #1 without thread: it sews from the start arrow upward following the outline (shown in red) on the **Left Border track** to the outline on the **Top Border track**.

It follows nothing between the two! Re-position if needed to follow the outlines on both tracks.

Add a basting box then turn it off. Advance to **Color #2**.

Thread Color #2 **Nutmeg (0932) # \_\_\_\_\_**  
Embroider the track.

Thread Color #3 **Black (0020) # \_\_\_\_\_**  
Embroider the outlining.

Remove the hoop from the module and the fabric from the hoop.  
Gently remove the stabilizer from the back.

Remove all the basting stitches.

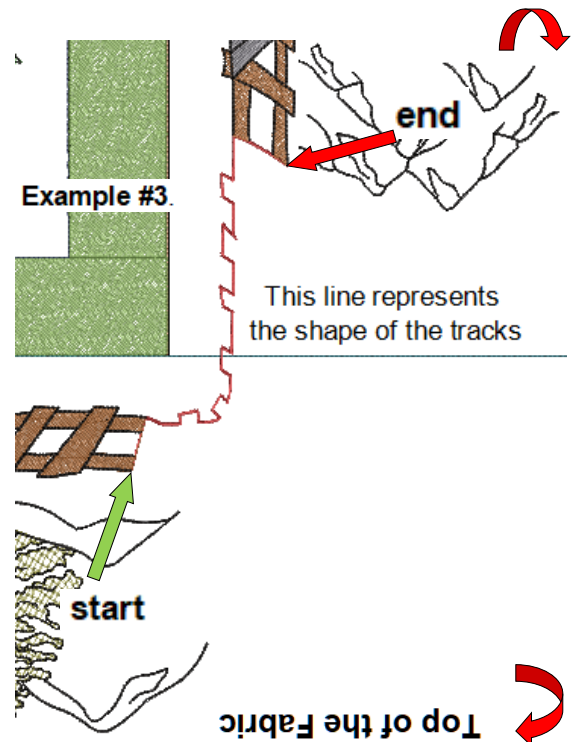
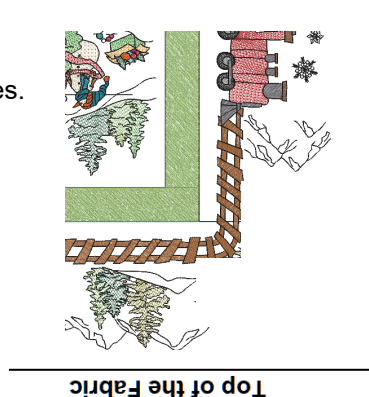



## 4 Borders / 5 Corners Folder / Hooping 4 Upper Left Trees

Attach the hoop and the grid (no fabric) to the module.

### Open #4 Upper Left Trees

**Step #1** Advance to the **embroidery sewing screen** to go to the 1<sup>st</sup> stitch of the design.

**Step #2** Lower the needle, lay an arrow shaped post it note on the grid with the tip of the arrow touching the needle. (The arrow is positioned about 1½" ABOVE & 2¼" to the LEFT of center on the grid.)

### Fabric Position:

To hoop this design the **Top of the Fabric is Rotated to the BOTTOM** of the hoop.

The fabric is upside down!

See **Example #4** below for **1st stitch** position.

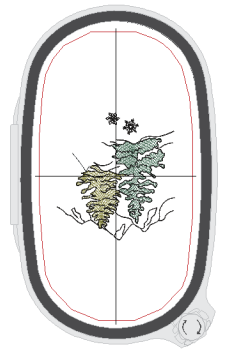
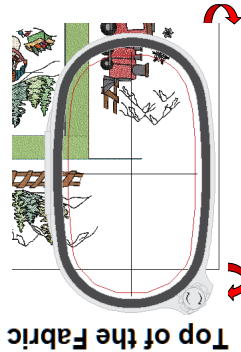

Hoop the fabric with the **arrow on the grid pointing to the green start arrow** see **Example #4**.

The SEAM lines on the quilt top must be parallel and perpendicular to the lines on the grid so you hoop straight.

**REMOVE** the grid from the hoop and attach the hoop to the module. **Float heavy weight tear away stabilizer** (sprayed with 505) **under the attached hoop**.

No Thread Color #1 **Placement Line**. The needle is positioned at the green start arrow see **Example #4**. The arrow on the grid points to the **upper left corner of the Rail on the curve of the track**. See green start arrow. Sew Color #1 without thread: it sews from the start arrow downward following the outline (shown in red) of the rail. Important to "Nail" the lower **left corner**.

Add a basting box then turn it off. Advance to **Color #2**.

Thread Color #2 **Green (c5324 w5934) # \_\_\_\_\_**  
Embroider the left tree.

Thread Color #3 **Yellowgreen (6043) # \_\_\_\_\_**  
Embroider the right tree.

Thread Color #4 **Black (0020) # \_\_\_\_\_**  
Embroider the outlining.

Remove the hoop from the module and the fabric from the hoop. Gently remove the stabilizer from the back.

Remove the basting stitches.

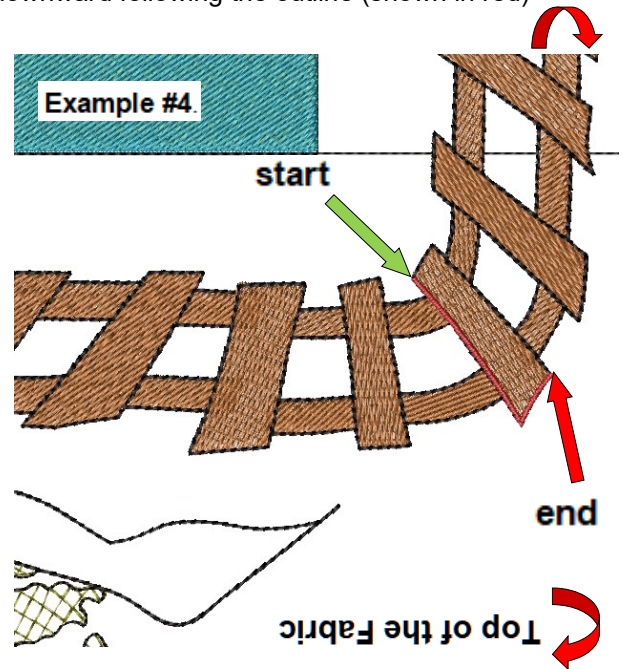

## 4 Borders / 5 Corners Folder / Hooping 5 Lower Left Corner

Attach the hoop and the grid (no fabric) to the module.

### Open #5 Lower Left Corner

**Step #1** Advance to the **embroidery sewing screen** to go to the 1<sup>st</sup> stitch of the design.

**Step #2** Lower the needle, lay an arrow shaped post it note on the grid with the tip of the arrow touching the needle. (The arrow is positioned about 1/2" ABOVE & 2 1/2" to the LEFT of center on the grid.)

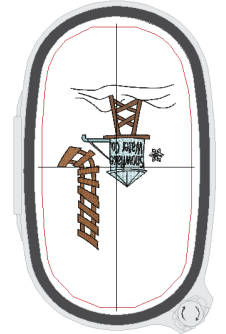

### Fabric Position:

To hoop this design the **Top of the Fabric is Rotated to the BOTTOM** of the hoop.

The fabric is upside down!

See **Example #5** below for **1st stitch** position.

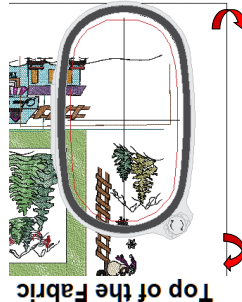

Top of the Fabric

Hoop the fabric with the **arrow on the grid pointing to the green start arrow** see **Example #5**.

The SEAM lines on the quilt top must be parallel and perpendicular to the lines on the grid so you hoop straight.

**REMOVE** the grid from the hoop and attach the hoop to the module.

**Float heavy weight tear away stabilizer** (sprayed with 505) **under the attached hoop**.

No Thread Color #1 **Placement Line**. The needle is positioned at the green start arrow see **Example #5**. The arrow on the grid points to the **upper left corner of the black outline**. Sew Color #1 without thread: it sews from the start arrow downward following the outline (shown in red) on the **Bottom Border** track to the outline on the **Left Border** track. It follows nothing between the two! Re-position if needed to follow the outlines on both tracks. Add a basting box then turn it off.

Advance to **Color #2**.

Thread Color #2 **Nutmeg #** \_\_\_\_\_  
Embroider the track.

Thread Color #3 **Blue (c4240 w3750) #** \_\_\_\_\_  
Embroider the top of the water tower.

Thread Color #4 **Pony (1233) #** \_\_\_\_\_  
Embroider the base of water tower.

Thread Color #5 **Black (0020) #** \_\_\_\_\_  
Embroider the outlining & mountains.

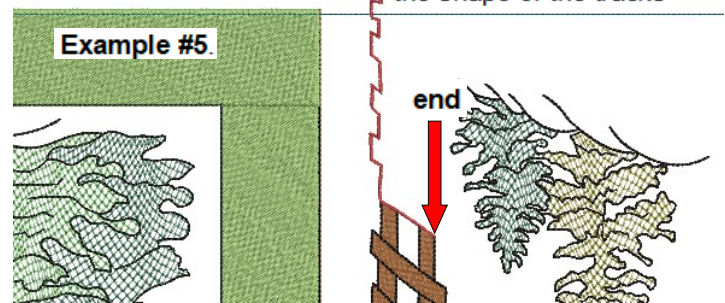
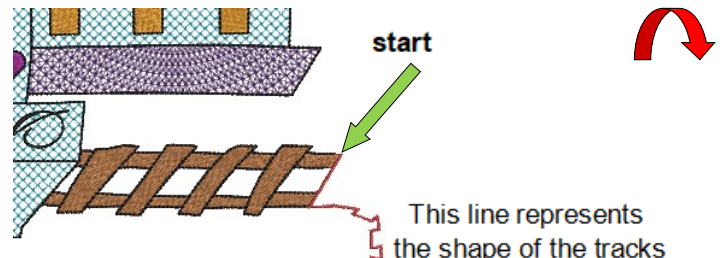

This line represents the shape of the tracks

Example #5

Remove the hoop from the module and the fabric from the hoop. Gently remove the stabilizer from the back.



Remove the basting stitches.

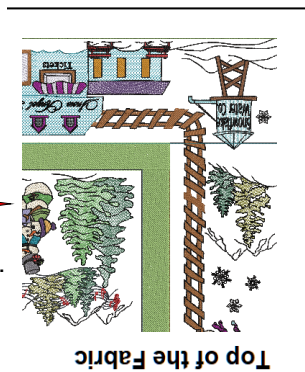

Top of the Fabric

Top of the Fabric



## 4 Borders / 5 Corners Folder / Hooping 6 Lower Right Track

Attach the hoop and the grid (no fabric) to the module.

### Open #6 Lower Right Track

**Step #1** Advance to the **embroidery sewing screen** to go to the 1<sup>st</sup> stitch of the design.

**Step #2** Lower the needle, lay an arrow shaped post it note on the grid with the tip of the arrow touching the needle. (The arrow is positioned about 1" BELOW & 2" to the LEFT of center on the grid.)

### Fabric Position:

To hoop this design the **Top of the Fabric** is positioned at the **TOP** of the hoop.

See **Example #6** below for 1<sup>st</sup> stitch position.

### Top of the Fabric

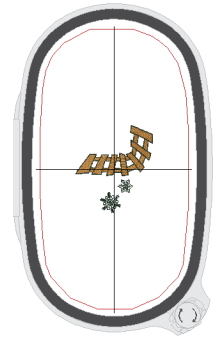
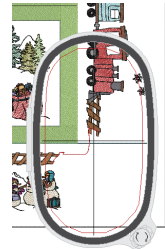

Hoop the fabric with the **arrow on the grid pointing to the green start arrow** see **Example #6**.

**REMOVE** the grid from the hoop and attach the hoop to the module.

**Float one piece of heavy weight tear away stabilizer** (sprayed with 505) **under the hoop**.

No Thread Color #1 **Placement Line**. The needle is positioned at the green start arrow see **Example #6**. The arrow on the grid points to the **beginning of the placement line**.

Sew Color #1 without thread: it sews from the start arrow upward following the black outline on the **Bottom Border track** (shown in red) to the outline on the **Right Border track**. It follows nothing between the two tracks.

Re-position if needed to follow the red Placement Line.

Add a basting box then turn it off.

Advance to **Color #2**.

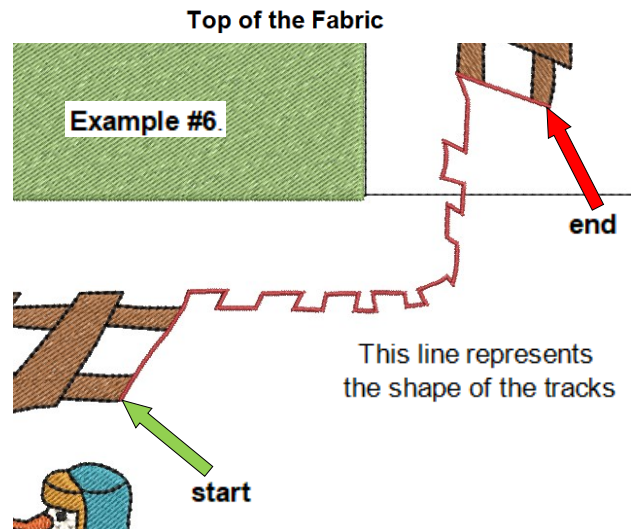

Thread Color #2 **Nutmeg (0932) # \_\_\_\_\_**  
Embroider the tracks.

Thread Color #3 **Black (0020) # \_\_\_\_\_**  
Embroider the outlining and snowflakes.

Remove the hoop from the module and the fabric from the hoop.

Gently remove the stabilizer & basting stitches from the back.



## 4 Borders / 5 Corners Folder / Hooping 7 Lower Right Trees

Attach the hoop and the grid (no fabric) to the module.

### Open #7 Lower Right Trees

**Step #1** Advance to the **embroidery sewing screen** to go to the 1<sup>st</sup> stitch of the design.

**Step #2** Lower the needle, lay an arrow shaped post it note on the grid with the tip of the arrow touching the needle. (The arrow is positioned about 1/2" BELOW & 2 1/2" to the LEFT of center on the grid.)

### Fabric Position:

To hoop this design the **Top of the Fabric** is positioned at the **TOP** of the hoop.

See **Example #7** below for 1st stitch position

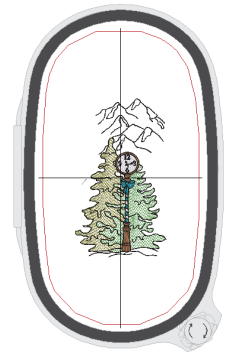
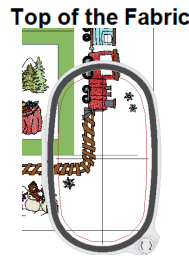

Hoop the fabric with the **arrow on the grid pointing to the green start arrow** see **Example #7**.

**REMOVE** the grid from the hoop and attach the hoop to the module.

**Float one piece of heavy weight tear away stabilizer** (sprayed with 505) **under the attached hoop**.

No Thread Color #1 **Placement Line**. The needle is positioned at the green start arrow see **Example #7**. The arrow on the grid points to the **green start arrow**. Sew Color #1 without thread: it sews from the lower left tip of the center rail upward (Placement Line shown in red) following the **outer edge** of the track to the end arrow.

Re-position if needed to follow the outline of the tracks.

Add a basting box then turn it off. Advance to **Color #2**.

Thread Color #2 **Green (c5510 w0345) # \_\_\_\_\_**  
Embroider the front tree.

Thread Color #3 **White (0015) # \_\_\_\_\_**  
Embroider the clock face.

Thread Color #4 **Yellowgreen (6043) # \_\_\_\_\_**  
Embroider the left tree.

Thread Color #5 **Pony (1233) # \_\_\_\_\_**  
Embroider the lamp post base.

Thread Color #6 **Blue (c4116 w3902) # \_\_\_\_\_**  
Embroider the stripes and bow on the post.

Thread Color #7 **Black (0020) # \_\_\_\_\_**  
Embroider the outlining.

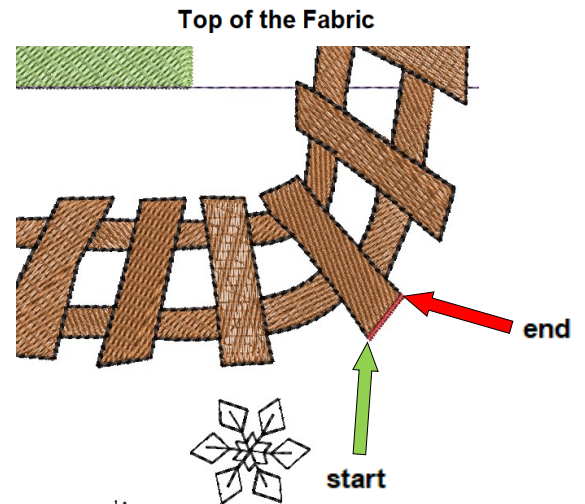

**Example #7.**

Remove the hoop from the module and the fabric from the hoop.

Gently remove the stabilizer & basting stitches from the back.





## Trim the Embroidered Borders

Always draw the “cutting lines” on the quilt top before actually trimming the borders to the size needed.

The Embroidered Borders will be trimmed to **about 6¼ wide +/-**.

The overall size after cutting the borders is **45½” square**.

Measure the drawn square to make sure it is 45½” before cutting.

Place a **Large Square & Straight Edge Ruler** across the quilt top to make sure the drawn lines are “square” with each other before cutting. In other words, the drawn Side Lines are perpendicular to the Top & Bottom lines.

You may need to make one border a little wider/narrower to get the 45 ½” square.

**Be very careful when cutting that the ruler doesn't shift or move!!!**

Trim the quilt top to 45½” square.

Outer edge of Embroidered Border before cutting

Newly drawn 45 ½” Square



## Outer Border Prep

The Quilt top measures **45½" square**.

### Outer Border Fabric

Cut the long length of the fabric in half.  
 (2) 22" x Length of Fabric  
 (set one aside for binding)

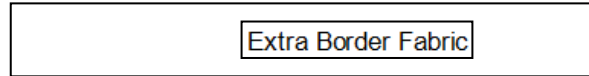

**Interfacing: Shape Flex 101 by Pellon** (see page #6 for instructions)

Iron **Shape Flex** to the wrong side of the **Outer Border Fabric**.

**WHY???????** The **Outer Border Fabric** will now have the same texture and weight like the rest of the Quilt top, making it easier to piece and quilt.

## Cut the Outer Borders

Cut **(4) 4" wide x Length of Border Fabric**

The width can be however wide you would desire!

Sew the **Left & Right** Borders to the Quilt top.

Pin frequently to avoid stretching.

Finger press the seams to the border then use iron to press.

Trim the side borders to height of the quilt.

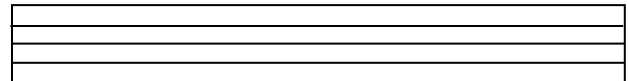

Sew the **Top & Bottom** borders accordingly to the Quilt top.

Pin frequently to avoid stretching.

Finger press the seams to the border then use the iron to press.

Trim the top & bottom borders to width of the quilt.

If you prefer narrower borders, trim the width of the Outer Border after sewing it to the quilt top.

Congratulations!!!! Time to quilt, bind...and enjoy!!

